

Measuring Amplifier
System

MGCplus

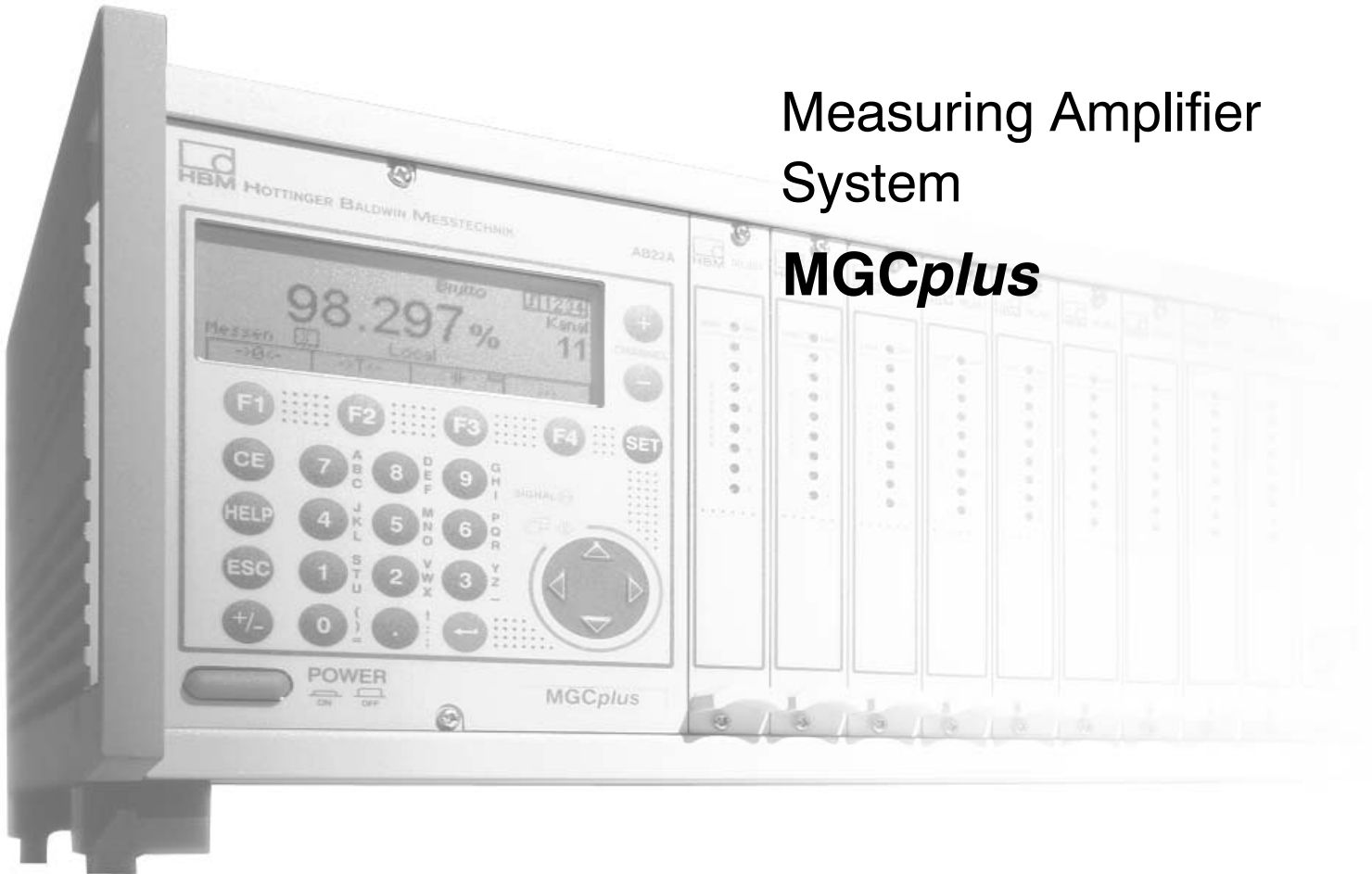

System devices

Mains supply NT030			
Supply voltage	V AC	85-264	
Max. power consumption	W	170	
Input frequency	Hz	40-65	
Start-up current	A	<16	
Battery supply NT031			
Battery voltage	V DC	8-36	
Max. power consumption	W	170	
Start-up current	A	<20	
Nominal (rated) temperature range	°C [°F]	1...16 slots, desktop housing -10 ... +55 [+14 ... +131]	19" rack frame -10 ... +55 [+14 ... +131]
Type of protection		desktop housing IP20	19" rack frame IP20

Dimensions desktop housing (w x h x d in mm) (1 mm = 0.03937 inches)

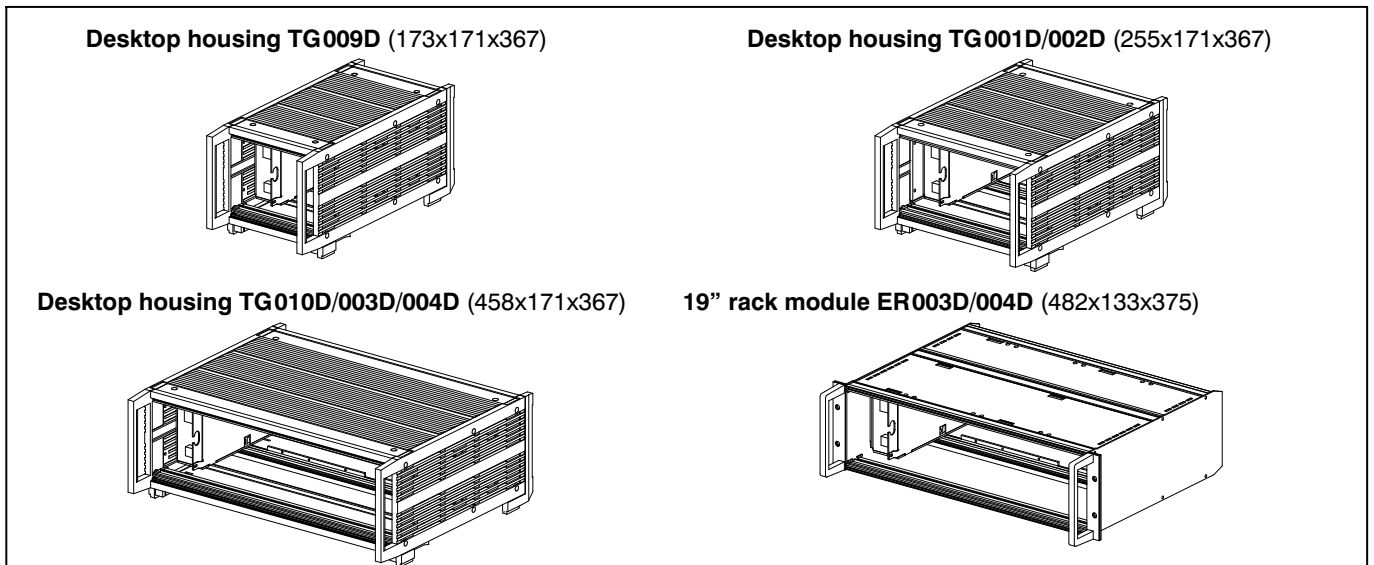

Desktop housing	Rack frame	Max. number of slots	Supply voltage (V)	Weight, approx. (kg) TG/ER
TG001D	-	6	230 V (115) ~	6
TG010D	-	6 (with AB32)	230 V (115) ~	8
TG002D	-	6	12/24 =	6
TG003D	ER003D	16	230 V (115) ~	7/6
TG004D	ER004D	16	12/24 =	7.5/6
TG009D	-	2	230 V (115) ~	5

Notes:

- The MGCplus system is tested according to the harmonized European standards EN61326 and EN61010. Therefore it achieves the protection aims of EEC directive 89/336EEC in the field of electromagnetic compatibility and EEC directive 73/23/EEC in the field of electrical safety of low voltage equipment. Mechanical stress is tested according to European Standard EN60068-2-6 for vibrations and EN60068-2-27 for shock. The equipment is exposed to an acceleration of 25 m/s² within the frequency range of 5...65 Hz in all 3 axes. Duration of this vibration test: 30 min per axis. The shock test is performed with a rated value of 200 m/s² acceleration during 11 ms, half sine pulse shape, with 3 shocks in each of the 6 possible directions.
- The maximum capacity of drawn current on each MGCplus slot is 150 mA in a 16 slots housing. The double capacity on every used slot is possible, if the next slot of each used one is left free.

System devices MGCsplit

1-NT650/1-NT651 power packs		
Input voltage range, nominal	V DC V DC	10 ... 50 12, 24 and 42 (suitable for all common automotive vehicle electrical systems)
Output voltage	V DC	28 ± 2%
Max. continuous output current	A	3,5
Max. number of connectable MGCsplit modules	-	10 (e.g. 1x SH400CP, 9x SH400 or SH650; one module less, if an ABX22 is connected)
Ride-through start-up Intrusion at > 8.5V	-	(ride-through times without measurement system failure) unlimited
NT650 only: Intrusion at < 8.5V	s	min. 10
Voltage discontinuity		(typical ride-through times without measurement system failure)
NT650:	s	10 at full load (100 W)
	s	60 at a load of 1x SH400CP42+ 2x SH650
NT651:	ms	15 at full load (100 W)
	ms	50 at a load of 1x SH400CP42+ 2x SH650
Start from standby mode	-	Via CAN message and digital control signal
Power consumption at standby mode	W	<1.2
CAN hardware bus link	-	Standard CAN as per ISO11898
Baud rate	kBits/s	250
Electrical isolation of digital input	V DC	500, typically
Input voltage range of digital input	V DC	0 ... 50
Input current of digital input	mA	< 3
Low level of digital input	V	< 1
High level of digital input	V	> 3
Protection against false operation	-	Sustained short-circuit proof, polarity reversal protection, cutoff at excess temperature
Degree of protection	-	IP65
Operating temperature range	°C	-20 ... +60
Nominal temperature range	°C	-20 ... +60
Permissible relative humidity	%	100
Connections	-	Power supply Split line IN / OUT CAN / digital input
Connection technique	-	ODU Minisnap, series B, design S3, size 2
Power supply		4-pin, 60° coding (suitable connector for cable mounting e.g. S32BFC-T04LPH0-6000)
Split line IN / OUT		16-pin, no coding (suitable connector for cable mounting e.g. S32B0C-T16PFG0-7500)
CAN / digital input		6-pin, 30° coding (suitable connector for cable mounting e.g. S32BAC-T06MPH0-6000)
Weight		
NT650	kg	3.15
NT651	kg	2.70
Dimensions (W x H x D)	mm	104 x 146 x 205

Modules ^{*)}		1-SH400	1-SH650	1-SH400CP
Function		Enclosure for one MLxx amplifier and max. two connection boards (each 4 divs wide)		Enclosure for the communication processor
Degree of protection		IP40	IP65	IP40
Operating temperature range	°C [°F]	-20 ... +60 [-4 ... +140]	-20 ... +60 [-4 ... +140]	-20 ... +60 [-4 ... +140]
Nominal (rated) temperature range	°C [°F]	-20 ... +60 [-4 ... +140]		
Permissible relative humidity	%	95 at 40 °C [104 °F]	100	95 at 40 °C [104 °F]
Supply voltage	V	18 ...32		
Connections	-	<ul style="list-style-type: none"> • Split-Line Input/Output • As on the resp. connection boards 	<ul style="list-style-type: none"> • Split-Line Input/Output • ODU connectors (Lemo[®] compatible) 	<ul style="list-style-type: none"> • Connection for ABX22A • With CP22 and CP42: 100 Mbit-Ethernet; USB; RS-232-C
Weight without amplifier and connection board, approx.	kg	1.6		
Dimensions (W x H x D)	mm	104 x 146 x 205		

^{*)} See MGCplus system specifications for measurement properties of amplifier modules.

Split-Line		
Total length	m	25 (from 1-SH400CP through last module)
Max. number of measurement modules	-	16
Baud rate	Meas./s	307,200; 4-byte format (like MGCplus)
Bus termination	-	Connected automatically

Enclosure dimensions MGCsplit (in mm; 1 mm = 0.03937 inches)

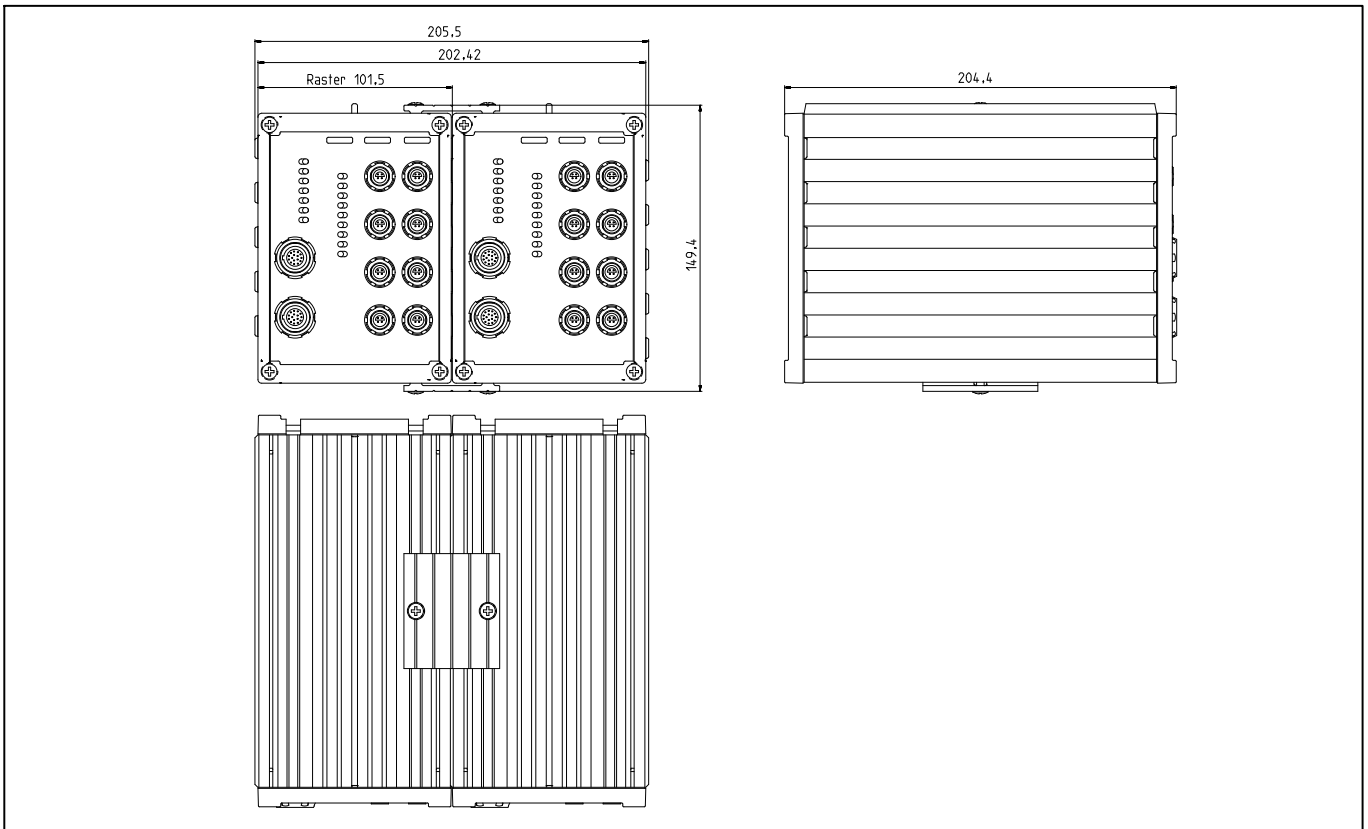

Mounting dimensions MGCsplit (in mm; 1 mm = 0.03937 inches)

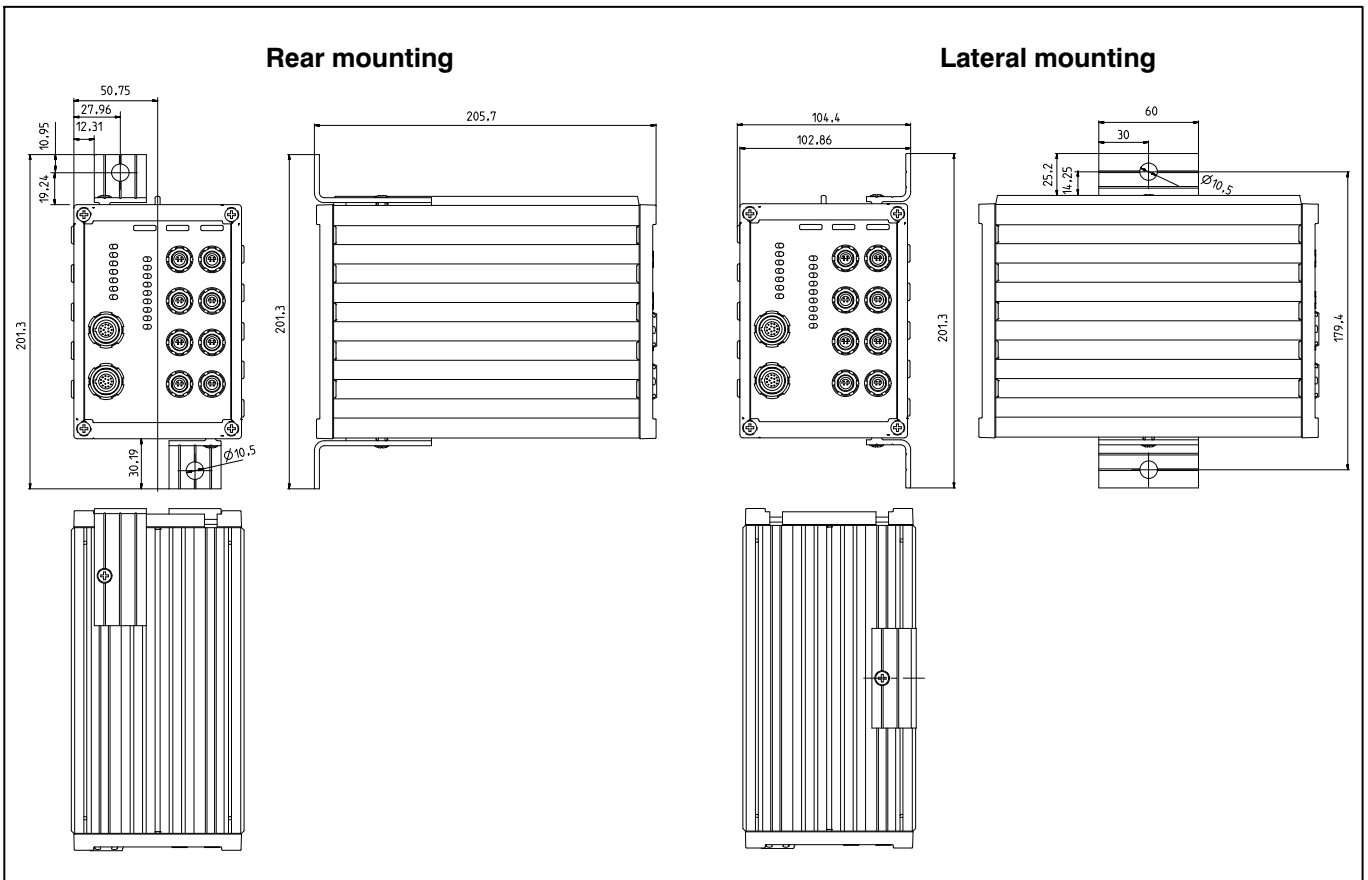

General technical data single-channel amplifier modules

Width	mm	20.3 (4 divs) ¹⁾
Maximum sampling rate without linearisation	values/s	19200
Limit value switches		
Number		4
Reference level		Gross, net, peak values
Reference voltage (freely adjustable)	%	-100 ... +100 of measuring range
Hysteresis factory setting	%	1 of measuring range
Adjustment accuracy	%	0.0033 of measuring range
Response time	ms	1.0 with Butterworth filter > 5 Hz and Bessel filter > 1.25 Hz
Peak value store		
Number		2
Function		Maximum, minimum
Peak combine		Peak-peak, average
Update time	µs	30 with Butterworth filter > 250 Hz and Bessel filter > 100 Hz
Clearing the peak value stores (switching to current value)		within 1 ms, via control inputs
Holding of the current value/peak value		within 1 ms, via control inputs
Time constant for envelope curve function	s	0.01 ... 10000
Control contacts (HCMOS)		
Inputs (8 lines, connectable as desired)		
Permissible input voltage	V	-0.5 to +5.5
High level	V	min. +4.0
Low level	V	max. +0.7
Schmitt-trigger, hysteresis	V	> 1.1
Pull-up resistors	kΩ	100
Outputs (limit value switch, error)		
High level with max. 1 mA	V	> 4.0
Low level with max. 0.7 mA	V	< 0.7
Internal resistance	kΩ	1
Nominal (rated) temperature range	°C [°F]	-20 ... +60 [-4 ... +140]
Service temperature range	°C [°F]	-20 ... +60 [-4 ... +140]
Storage temperature range	°C [°F]	-25 ... +70 [-13 ... +158]
Operating voltages	V	± 14.6...17.0; (< 120 mA) ± 7.7...8.3; (< 120 mA) ²⁾ +4.9...5.1; (< 150 mA)
Card format (Euro)	mm	100 x 160
Weight	g	300
Connection plug		IEC 603-2 indirectly
Analog outputs V_{o1} and V_{o2}		
Nominal (rated) voltage	V	± 10 V (asymmetrical)
Permissible load resistance	kΩ	> 5
Internal resistance	Ω	< 5
The two output voltages can be used to display the five signal voltages.		Amplifier output with zero balance Output staggered by the tare value Peak value store 1 output (maximum or minimum) Peak value store 2 output (maximum or minimum) Peak value store 3 output (peak combine of 1 and 2)
Max. deviation of the analog outputs from the digital value	mV	< 3 (< 10 with ML10B)
Monitor output for V_{o1} via BNC plug on front panel		
Nominal (rated) voltage	V	± 10 (asymmetrical)
Permissible load resistance	kΩ	> 1000
Internal resistance	kΩ	1
Effect of a 10K-change of the ambient temperature (effect additional to digital value) on the outputs V _{o1} and V _{o2} :		
sensitivity	%	< 0.08, typ. 0.04
zero point	mV	< 3 typ. 2

¹⁾ With ML38B: 40.6 mm (8 divs)

²⁾ Also connectable to ± 16 V

ML01B single-channel amplifier modules

Accuracy class		0.03					
DC amplifier							
Input for voltage measurement							
		symmetrical					
Input signal range (selectable)	V	-10.2 ... +10.2	-0.0765 ... +0.0765				
Measuring range (digitally adjustable)	V	±0.4 ... 10.2	±0.002 ... 0.0765				
Zero offset	V	±10	±0.075				
Measuring frequency range	Hz	0 ... 2400 -1 dB ¹⁾	0 ... 250 -1 dB				
Internal resistance of the signal voltage source	kΩ	< 1.3					
Input for thermocouple measurement							
Measuring range (digitally adjustable)	°C, [°F]	10 ... 3275, [50 ... 5927]					
Linearisation error (with AP09 connection board)							
	°C	< 0.06					
	°C	< 0.25 (K, J, T, E, N)					
	°C	< 0.6 (S, B, R)					
Linearisation range							
NiCr-Ni (K)	°C	-158 ... +1414	-191 ... +1414				
Fe-CuNi (J)	°C	-167 ... +1192	-190 ... +1192				
Cu-CuNi (T)	°C	-210 ... +393	-237 ... +393				
NiCr-CuNi (E)	°C	-161 ... +1005	-205 ... +1005				
NiCrSi-NiSi (N)	°C	-186 ... +1300	-219 ... +1300				
Pt10Rh-Pt (S)	°C	+181 ... +1755	-50 ... +1755				
Pt30Rh-Pt6Rh (B)	°C	+570 ... +1814	+160 ... +1814				
Pt13Rh-Pt(R)	°C	+178 ... +1769	-50 ... +1769				
Max. internal resistance	kΩ	1.3					
Temperature range for cold junction ²⁾	°C, [°F]	-20 ... + 60, [-4 ... +140]					
Max. permissible common-mode voltage							
	V	62					
Input for current measurement							
		asymmetrical (to an internal 50 Ω standard resistor)					
Input signal range	mA	-50 ... +50					
Measuring range (digitally adjustable)	mA	±4 ... 50					
Max. measuring frequency range	Hz	0 ... 2400 -1 dB					
Zero offset, adjustable ("living" zero point)	mA	0 ... 50					
Measuring frequency range		Nom. val. fc	-1dB	-3dB	Phase del.	Rise time	Over-shoot %
Butterworth low pass		(Hz)	(Hz)	(Hz)	(ms)	(ms)	
		2400 ³⁾	2400	3250	0.28	0.105	5.2
		2000 ³⁾	2050	2350	0.40	0.170	12
		1000 ⁴⁾	1050	1190	0.66	0.336	12
		500	500	588	0.90	0.64	11
		250	246	291	1.45	1.3	10
		80	79	99	3.65	3.8	9
		40	37.5	49.5	6.0	7.0	7
		20	19	25.5	11	13.3	6
		10	8.9	12.4	20	26	5
		5	4.5	6.2	42	50	4
Bessel low pass		Nom. val. fc	-1dB	-3dB	Phase del.	Rise time	Over-shoot %
		(Hz)	(Hz)	(Hz)	(ms)	(ms)	
		1100 ⁴⁾	1100	1780	0.45	0.23	1.3
		400	445	805	0.7	0.45	1.3
		200	235	410	1.1	0.86	1.3
		100 ^{*)}	117	210	1.8	1.7	1.3
		40	38.5	68	4.3	5.1	1
		20	22.0	37.5	7.4	9.4	1
		10	10.5	19.0	12	19.0	0
		5	5.1	9.6	22	35.5	0
		2.5	2.6	4.8	50	70	0
		1.25	1.35	2.4	100	135	0
		0.5	0.7	1.2	200	280	0
		0.2	0.17	0.3	650	1100	0
		0.1	0.08	0.15	1400	2200	0
		0.05	0.043	0.075	3000	4600	0
High-pass⁵⁾							
from 0.2 Hz Be; 5 Hz Bu		Hz			0.1		
from 2.5 Hz Be; 5 Hz Bu		Hz			1.0		
from 20 Hz Be; 40 Hz Bu		Hz			10		
Absolute calibration deviation					0.1 ⁶⁾		
Linearity deviation		%	< 0.02 typ. 0.01 % of full scale ⁷⁾				
Noise rel. to input with filter setting		Hz		1.25		100	
MR: 75 mV		μV _{PP}		3		75	
MR: 10 V		μV _{PP}		40		120	
Thermocouples		Type K, J, T, E, N	K		typ. 0.1		
		Type S, B, R	K		typ. 1		

^{*)} Factory setting

¹⁾ With $V_I > 2.5$ V_{pp}, note limited measuring frequencies

³⁾ Valid for $V_{Ipp} < 2.5$ V with Range = 10 V (corresp.)

⁵⁾ In the case of resistance thermometers and thermocouples: no function

²⁾ Cold junction included in AP09 connection board

⁴⁾ Valid for $V_{Ipp} < 5$ V with Range = 10 V (corresp. to 50 % modulation of range)

⁶⁾ 0.2 % with current measurement

⁷⁾ For measuring ranges > 3 V or > 25 mV or > 10 mA; otherwise < 0.1 % of full 25 % modulation of range) scale.

ML01B single-channel amplifier module (continued)

Long-term drift over 48 hours (Autocalibration on/off) Meas. range 75 mV Meas. range 10 V Thermocouples (Autocalibration on/off) Type J, T Type E, K, N Type S, B, R	μV mV K K K	5 / 10 0.5 / 1 0.25 / 0.5 0.5 / 1 1 / 2
Effect of a 10 K-change of the ambient temperature on the digital signals S1 and S2 with autocalibration on/off Sensitivity Zero point 10 V range 75 mV range 20 mA range Thermocouples Type J, T Type E, K, N Type S, B, R	% mV μV μA K K K	< 0.02 typ. 0.01 / < 0.2 typ.0.1 < 0.2 / < 6 < 5 / < 50 < 4 / < 120 0.25 / 2.5 0.5 / 5 1 / 10
Analog outputs V_{O1} and V_{O2} Residual carrier voltage (38.4 kHz) Long-term drift (over 48 h)	mV _{PP} mV	< 12 < 3

ML10B single-channel amplifier module

Accuracy class	0.03						
Bridge excitation voltage ($\pm 5\%$) Transducers S.G. half and full bridges, potentiometers, piezoresistive transducers S.G. quarter bridge Piezoelectric transducer Current-fed piezoelectric transducers (e.g. Deltatron® from Brüel&Kjaer)	V Ω	10 220...5000	5*) 110...5000	2.5 60...5000	1 30...5000		
Perm. cable length between transducer and amplifier	m	max. 500 ¹⁾					
DC amplifier Measuring ranges Strain gages (Low) Potentiometers, piezoresistive transducers (High) Charge amplifiers Bridge balancing range Strain gages (Low) Potentiometers, piezoresistive transducers (High) Charge amplifiers Measuring frequency range Butterworth low pass	mV/V mV/V mV/V mV/V V	$\pm 0.10...3.06$ $\pm 10...306$	$\pm 0.20...6.12$ $\pm 20...612$	$\pm 0.40...12.24$ $\pm 40...1224$	$\pm 1.0...30.6$ $\pm 100...3060$		
		Voltage input with max. ± 2.5 V amplitude					
		± 3.06 ± 306	± 6.12 ± 612	± 12.24 ± 1224	± 30.6 ± 3060		
		± 2.5 V					
		Nom. val. (Hz)	fc -1dB (Hz)	-3dB (Hz)	Phase del. (ms)	Rise time (ms)	Overshoot %
		10000	8900	9900	0.13	0.05	19 ²⁾
		3000	2920	3480	0.16	0.116	13
		2000	2160	2500	0.24	0.15	12
		1000	1010	1165	0.66	0.35	12
		500	500	588	0.9	0.64	11
		250	246	291	1.45	1.3	10
		80	79	99	3.65	3.8	9
		40	37.5	49.9	6	7	7
		20	19	25.5	11	13.3	6
		10	8.9	12.4	20	26	5
		5	4.5	6.2	42	50	4

*) Factory setting

1) 100 m max. distance between connection board and T-ID/TEDS module

2) For a max. of 25 % modulation ($U_{APPmax}=5$ V)

ML10B single-channel amplifier module (continued)

Measuring frequency range		Nom. val.	fc	-1dB	-3dB	Phase del.	Rise time	Overshoot	
Bessel low pass		(Hz)	(Hz)	(Hz)	(ms)	(ms)	(ms)	%	
Analog output only (Digital interface 5000 Hz Butterworth)	}	100000	111000	188000	0.0027	0.0025	10.8	(High)	
		100000	104000	145000	0.0027	0.0025	10.8	(Low)	
		50000	49000	84000	0.0044	0.004	6.6		
			1000	900	1800	0.27	0.2	0.6	
			400	400	800	0.47	0.44	0.5	
			200	230	405	0.82	0.96	0.4	
			100 ^{*)}	117	210	1.58	1.8	0.4	
			40	38.5	68	4.21	5.4	0	
			20	22	37.5	7.2	9.3	0	
			10	10.5	19	13.9	19	0	
			5	5.1	9.6	25	37	0	
			2.5	2.6	4.8	50	75	0	
			1.25	1.35	2.4	100	155	0	
			0.5	0.7	1.2	200	300	0	
			0.2	0.17	0.3	650	1200	0	
			0.1	0.08	0.15	1400	2300	0	
			0.05	0.043	0.075	3000	4600	0	
High-pass	from 0.2 Hz Be; 5 Hz Bu	Hz			0.1				
	from 2.5 Hz Be; 5 Hz Bu	Hz			1.0				
	from 20 Hz Be; 40 Hz Bu	Hz			10				
Max. permissible common-mode voltage	V	± 6							
Common-mode-rejection	dB	> 120 (DC)							
Strain gages	dB	> 95 (DC)							
Potentiometers	%	< 0.03 typ. 0.02 full scale							
Linearity deviation	μV/V	< 0.1/0.2							
Long-term drift over 48 hours (Autocalibration on/off)		Strain gage		Potentiometer					
Interference voltages at the output		(0.2...6.12 mV/V)		(20...612 mV/V)					
Noise related to the input									
with Bessel low pass		100000 Hz		4		300			
		50000 Hz	μV/V _{pp}	3 ¹⁾		300			
		10000 Hz		3		300			
		1000 Hz		1.3		100			
		100 Hz		0.35		35			
Effect of a 10 K-change of the ambient temperature on the digital signals S1 and S2		with autocalibration on:			with autocalibration off:				
Strain gage (Low):	sensitivity	%		<0.03		<0.2			
	zero point	μV/V		<0.6		<10			
Potentiometer (High):	sensitivity	%		<0.03		<0.2			
	zero point	μV/V		<30		<500			
Long-term drift over 48 hours				<0.25		<5			
Strain gage (Low):		μV/V		<20		<400			
Potentiometer (High):		μV/V							
Analog outputs V_{o1} and V_{o2}									
Residual carrier voltage	mV _{pp}						<5		
Long-term drift (over 48 h)	mV						<3		

^{*)} Factory setting

¹⁾ For half bridge 20 μV/V. We recommend that you measure only up to a cut-off frequency of 10 kHz.

ML30B single-channel amplifier module

Accuracy class		0.03					
Carrier frequency	Hz	600.15 ± 0.06 (synchronised) 600.00 ± 0.04 (not synchronised)					
Bridge excitation voltage (± 5 %)	V	5*	2.5	1			
Transducers S.G. full bridge	Ω	110...5000 (V _B = 5 V) 60...5000 (V _B = 2.5 V) 30...5000 (V _B = 1 V)					
S.G. quarter bridge		In conjunction with AP14 connection board					
Perm. cable length between transducer and amplifier	m	500 max.					
Carrier frequency amplifier							
Measuring ranges	mV/V	± 0.1000 ... 3.0600 (V _B = 5 V) ± 0.2000 ... 6.1200 (V _B = 2.5 V) ± 0.5000 ... 15.3000 (V _B = 1 V)					
Bridge balance range	mV/V	± 3.06 (V _B = 5 V) ± 6.12 (V _B = 2.5 V) ± 15.3 (V _B = 1 V)					
Measuring frequency range Butterworth low pass		Nom. val.	fc -1dB	-3dB	Phase del.	Rise time	Over-shoot %
		(Hz)	(Hz)	(Hz)	(ms)	(ms)	
		200	235	277	2.5	1.4	10
		80	88	103	4.6	3.8	9
		40	43	51	8.2	7.4	7
		20	22	26	14	14	6
		10	10.6	12.7	27	30	5
		5	5.3	6.3	52	56	4
Bessel low pass		Nom. val.	fc -1dB	-3dB	Phase del.	Rise time	Over-shoot %
		(Hz)	(Hz)	(Hz)	(ms)	(ms)	
		100*	99	180	2.7	2	1
		40	40	72	5.2	4.8	1
		20	20	35.5	9.8	10	1
		10	9.8	18	18	20	0
		5	4.4	8.6	35	40	0
		2.5	2.35	4.4	65	80	0
		1.25	1.2	2.15	125	160	0
		0.5	0.6	1.15	220	300	0
		0.2	0.17	0.31	640	1100	0
		0.1	0.087	0.155	1400	2200	0
		0.05	0.042	0.08	3000	4600	0
High-pass	Hz	0.1					
from 0.2 Hz Be; 5 Hz Bu	Hz	1.0					
from 2.5 Hz Be; 5 Hz Bu	Hz	10					
from 20 Hz Be; 40 Hz Bu							
Max. permissible common-mode voltage	V	± 6 V					
Common-mode-rejection	dB	> 50 (0 ... 600 Hz)					
Max. differential voltage DC	V	± 0.1					
Residual carrier voltage (600 Hz)	μV/V _{PP}	< 0.3 ¹⁾					
Noise	μV/V _{PP}	< 0.3 (0...200 Hz) < 0.03 (0...1.25 Hz)					
Effect of a 10 K-change of the ambient temperature on the digital signals S1 (gross) and S2 (net):							
with autocalibration on:	sensitivity	% < 0.01 typ. 0.005 %					
	zero point	μV/V < 0.1					
with autocalibration off:	sensitivity	% < 0.2					
	zero point	μV/V < 2					
Linearity deviation	%	< 0.02 typ. 0.01 of full scale ²⁾					
Long-term drift over 48 hours (Autocalibration on / off)	μV/V	< 0.1 / 2					
Analog outputs V_{o1} and V_{o2}							
Residual carrier voltage	mV _{PP}	< 3					
Long-term drift (over 48 h)	mV	< 3					

^{*)} Factory setting

¹⁾ Measured with V_B = 5 V and input signal 2 mV/V

²⁾ For ranges > 1 mV/V (V_B = 5 V); otherwise < 0.2 %

ML35B single-channel amplifier module

Accuracy class		0.03
Carrier frequency	Hz	75
Transducers		
Resistors	Ω	0...5000
Resistance thermometers		Pt10, Pt100, Pt1000
Perm. cable length between transducer and amplifier	m	200 ¹⁾ to 5000 Ω , PT1000 500 ¹⁾ to 500 Ω , PT10, PT100
Carrier frequency amplifier		
Measuring ranges	Ω	20 ... 500; 200 ... 5000
Supply current	mA_{eff}	1; 0.1
Measuring frequency range		Nom. val. fc -1dB -3dB Phase del. Rise time Over-
Butterworth low pass		(Hz) (Hz) (Hz) (ms) (ms) shoot %
		15 16 23 22 16 7
		10 8.6 12.2 30 30 5
		5 5.3 6.3 52 56 4
Bessel low pass		Nom. val. fc -1dB -3dB Phase del. Rise time Over-
		(Hz) (Hz) (Hz) (ms) (ms) shoot %
		15 15 27 18 15 1.2
		10 9.8 18 24 20 0
		5 4.4 8.6 35 40 0
		2.5 2.35 4.4 65 80 0
		1.25 1.2 2.15 125 160 0
		0.5 0.6 1.15 220 300 0
		0.2 0.17 0.31 640 1100 0
		0.1 0.087 0.155 1400 2200 0
		0.05 0.042 0.08 2700 3700 0
High-pass ²⁾	Hz	0.1
from 0.2 Hz Be; 5 Hz Bu	Hz	1.0
from 2.5 Hz Be; 5 Hz Bu	Hz	10
from 20 Hz Be; 40 Hz Bu		
Linearity deviation		
0...500 Ω	Ω	± 0.1
0...5000 Ω	Ω	± 1
Pt10	K	± 2.5
Pt100	K	± 0.25
Pt1000	K	± 0.25
Effect of a 10K-change of the ambient temperature on the digital signals S1 (gross) and S2 (net); with autocalibration on:		
sensitivity	%	< 0.015 typ. 0.0075 %
zero point	$\text{m}\Omega$	< 10 (Measuring range 500 Ω)
	$\text{m}\Omega$	< 100 (Measuring range 5000 Ω)
with autocalibration off:		
sensitivity	%	< 0.2
zero point	Ω	< 0.5 (Measuring range 500 Ω)
	Ω	< 5 (Measuring range 5000 Ω)
Long-term drift (over 48 h) (Autocalibration on)	$\text{m}\Omega$	< 10 (Measuring range 500 Ω)
		< 100 (Measuring range 5000 Ω)
Analog outputs V_{o1} and V_{o2}		
Residual carrier voltage	mV_{pp}	< 3
Long-term drift (over 48 h)	mV	< 3

¹⁾ 100 m max. distance between connection board and T-ID/TEDS module

²⁾ Function not available with resistance thermometers and thermocouples

ML38B single-channel amplifier module

Accuracy class		0.0025³⁾							
Accuracy	%	$\pm (0.0025 \text{ of measured value} + 0.0025 \text{ of full scale value})$							
Carrier frequency Bridge excitation voltage ($\pm 5\%$) Transducers Strain gage full bridge Perm. cable length between transducer and amplifier	V Ω m	225.05 \pm 0.02 5*) 2.5 30...4000; typ. 350 500 max.							
Carrier frequency amplifier Measuring ranges Bridge balancing range	mV/V mV/V	$\pm 0.2...5.1 (V_B = 5 \text{ V})$ $\pm 0.4...10.2 (V_B = 2.5 \text{ V})$ $\pm 5.1 (V_B = 5 \text{ V})$ $\pm 10.2 (V_B = 2.5 \text{ V})$							
Measuring frequency range Butterworth low pass		Filter levels							
Nominal (rated) value	Hz	f1	f2	f3	f4	f5	f6	f7	f8
f (-3 dB)	Hz	1.0	1.5	2.5	3	5	6	9	10
f (attenuation=1000)	Hz	1.1	1.6	2.3	3.2	4.6	6.3	8.3	10
f (attenuation=1000000)	Hz	18.9	21.6	24.5	27.4	30.5	33.8	37.3	41
Settling time to 99 %	s	50	54	57	61	65	68	70	72
Settling time to 99.999 %	s	1	0.7	0.5	0.37	0.26	0.2	0.16	0.13
	s	2.3	1.6	1.14	0.82	0.58	0.42	0.30	0.23
Bessel low pass		Filter levels							
Nominal (rated) value	Hz	f1	f2	f3	f4	f5	f6	f7	
f (-3 dB)	Hz	0.03	0.05	0.1	0.2	0.5	0.9	1.5	
f (attenuation=1000)	Hz	0.03	0.05	0.1	0.22	0.45	0.9	1.7	
f (attenuation=1000000)	Hz	0.125	0.25	0.5	1	2	4	8	
Settling time to 99 %	s	0.2	0.4	0.8	1.7	3.5	7	14	
Settling time to 99.999 %	s	32	16	8	4	2	1	0.5	
	s	48	24	12	6	3	1.5	0.75	
Display resolution	digit	1 000 000							
Transducer adaptation		linear or polynomial characteristic ⁴⁾							
Common-mode rejection Input resistance Effect of 10 K change in ambient temperature on digital signals S1 (gross) and S2 (net) Sensitivity Zero point Linearity deviation Long-term drift over 24 hours Short-term drift over 5 min, from 2h after switching on Sampling rate	dB M Ω % % % ppm ppm 1/s	>100 1000 < 0.002 of measured value < 0.001 of full scale value < 0.002 max. ± 20 , typ. ± 8 max. ± 10 , typ. ± 3 1.18/2.34/4.69/9.38/18.75/37.5/75							
Analog outputs Vo1 and Vo2 Residual carrier voltage Long-term drift (over 48 h)	mV _{PP} mV	< 3 < 3							

*) Factory setting

3) In the event of irradiation in accordance with EN 61326, table 1

4) Note: When calibrating the measurement chain, measured values have to be acquired in the electrical unit (mV/V) without display adaptation.

ML50B single-channel amplifier module

Accuracy class		0.03						
Carrier frequency	Hz	4801.2 ± 0.48 (synchronised) 4800.0 ± 0.32 (not synchronised)						
Bridge excitation voltage (± 5 %)	V	2.5*) 1						
Transducers Inductive half and full bridge	mH	2.5 ... 30 (V _B = 2.5 V) 1 ... 30 (V _B = 1 V) ¹⁾						
Perm. cable length between transducer and amplifier	m	500 max.						
Carrier frequency amplifier								
Measuring ranges	mV/V	± 6.00 ... 183.60 (V _B = 2.5 V) ± 15.00 ... 459.00 (V _B = 1 V)						
Bridge balance range	mV/V	± 183.6 (V _B = 2.5 V) ± 459 (V _B = 1 V)						
Measuring frequency range Butterworth low pass		Nom. val.	fc	-1dB	-3dB	Phase del.	Rise time	Over-
		(Hz)	(Hz)	(Hz)	(ms)	(ms)	(ms)	shoot %
		1500	1600	2180	0.32	0.17		7
		1000	1010	1165	0.66	0.35		12
		500	500	588	0.9	0.64		11
		250	246	291	1.45	1.3		10
		80	79	99	3.65	3.8		9
		40	37.5	49.5	6	7		7
		20	19	25.5	11	13.3		6
		10	8.9	12.4	20	26		5
		5	4.5	6.2	42	50		4
Bessel low pass		Nom. val.	fc	-1dB	-3dB	Phase del.	Rise time	Over-
		(Hz)	(Hz)	(Hz)	(ms)	(ms)	(ms)	shoot %
		900	900	1550	0.47	0.25		4.1
		400	445	805	0.7	0.45		1.3
		200	235	410	1.1	0.86		1.3
		100*	117	210	1.8	1.7		1.3
		40	38.5	68	4.3	5.1		1
		20	22	37.5	7.4	9.4		1
		10	10.5	19	12	19		0
		5	5.1	9.6	22	35.5		0
		2.5	2.6	4.8	50	70		0
		1.25	1.35	2.4	100	135		0
		0.5	0.7	1.2	200	280		0
		0.2	0.17	0.3	650	1100		0
		0.1	0.08	0.15	1400	2200		0
		0.05	0.043	0.075	3000	4600		0
High-pass	Hz	from 0.2 Hz Be; 5 Hz Bu						
	Hz	from 2.5 Hz Be; 5 Hz Bu						
	Hz	from 20 Hz Be; 40 Hz Bu						
Max. permissible common-mode voltage	V	± 6 V						
Common-mode rejection	dB	> 50 (0 ... 4800 Hz)						
Max. differential voltage DC	V	± 1						
Linearity deviation	%	< 0.02 typ. 0.01 of full scale ²⁾						
Residual carrier voltage (4800 Hz)	μV/V _{pp}	< 0.3 ³⁾						
Noise	μV/V _{pp}	< 100 (0...1500 Hz) < 50 (0...100 Hz) < 5 (0...1.25 Hz)						
Long-term drift over 48 hours (Autocalibration on / off)	μV/V	< 20 / 60						
Effect of a 10 K-change of the ambient temperature on the digital signals S1 (gross) and S2 (net):								
with autocalibration on:								
sensitivity	%	< 0.03 typ. 0.002 %						
zero point	μV/V	< 20						
with autocalibration off:								
sensitivity	%	< 0.2						
zero point	μV/V	< 120						
Analog outputs V_{o1} and V_{o2}								
Residual carrier voltage (38.4 kHz)	mV _{pp}	< 5						
Long-term drift (over 48 h)	mV	< 3						

*) Factory setting

2) For measuring ranges > 60 mV/V (V_B = 2.5 V); otherwise < 0.2 %

1) With Zener barriers only V_B = 1 V

3) Measured with V_B = 2.5 V and 80 mV/V input signal

ML55B single-channel amplifier module

Accuracy class		0.03	
Carrier frequency	Hz	4801.2 ± 0.48 (synchronised) 4800.0 ± 0.32 (not synchronised)	
Bridge excitation voltage (± 5 %)	V	5*)	2.5 1
Transducers¹⁾ Strain-gage half and full bridge	Ω	110 ... 5000 (V _B =5 V) 60 ... 5000 (V _B = 2.5 V) 30 ... 5000 (V _B = 1 V)	
Inductive half and full bridge	mH	2.5 ... 30 (V _B = 2.5 V) 1 ... 30 (V _B = 1 V)	
Absolute calibration deviation	%	0.1	
S.G. quarter bridge		In conjunction with AP14 connection board	
Perm. cable length between transducer and amplifier	m	500 ²⁾	
Carrier frequency amplifier			
Measuring ranges Strain gage	mV/V	± 0.1000 ... 3.0600 (V _B = 5 V) ± 0.2000 ... 6.1200 (V _B = 2.5 V) ± 0.5000 ... 15.3000 (V _B = 1 V)	
Inductive		± 1.5000 ... 45.9000 (V _B = 5 V) ± 3.0000 ... 91.8000 (V _B = 2.5 V) ± 7.500 ... 229.500 (V _B = 1 V)	
Bridge balance range Strain gage	mV/V	± 3.0600 (V _B = 5 V) ± 6.1200 (V _B = 2.5 V) ± 15.3000 (V _B = 1 V)	
Inductive		± 45.900 (V _B = 5 V) ± 91.8000 (V _B = 2.5 V) ± 229.500 (V _B = 1 V)	
Measuring frequency range Butterworth/Bessel low pass		see technical data ML50B	
High-pass from 0.2 Hz Be; 5 Hz Bu	Hz	0.1	
from 2.5 Hz Be; 5 Hz Bu	Hz	1.0	
from 20 Hz Be; 40 Hz Bu	Hz	10	
Max. permissible common-mode voltage	V	± 6 V	
Common-mode rejection	dB	> 50 (0 ... 4800 Hz)	
Max. differential voltage DC	V	± 1	
Linearity deviation	%	< 0.02 typ. 0.01 ³⁾	
Noise	μV/V _{pp}	Strain gage < 2 (0...1500 Hz) < 1 (0... 100 Hz) < 0.2 (0... 1.25 Hz)	Inductive < 100 (0...1500 Hz) < 50 (0..100 Hz) < 5 (0...1.25 Hz)
Long-term drift over 48 hours (Autocalibration on / off)	μV/V	< 0.2 / 4 < 20 / 60	
Effect of 10 K change in ambient temperature on digital signals S1 and S2		Strain gage	Inductive
with autocalibration on			
Sensitivity	%	< 0.02	
Zero point	μV/V	0.2	< 4
with autocalibration off			
Sensitivity	%	< 0.2	
Zero point	μV/V	4	60
Analog outputs Vo1 and Vo2			
Residual carrier voltage	mV _{pp}	< 5	
Long-term drift (over 48 h)	mV	< 3	

*) Factory setting

1) With bridge resistances of R_B>500 Ω, resistors of R_B/2 have to be integrated in the feedback circuits.

2) 100 m max. distance between connection board and T-ID/TEDS module

3) For measuring ranges > 1 mV/V strain gage (V_B = 5 V) or > 30 mV/V inductive; otherwise < 0.2 %

ML55BS6 single-channel amplifier module

Accuracy class		0.03																																																																																										
Carrier frequency	Hz	9602.4 ± 0.96 (synchronised) 9600.0 ± 0.32 (not synchronised)																																																																																										
Bridge excitation voltage (± 5 %)	V	5*) 2.5 1																																																																																										
Transducers Strain-gage half and full bridge	Ω	110 ... 5000 (V _B =5 V) 60 ... 5000 (V _B = 2.5 V) 30 ... 5000 (V _B = 1 V)																																																																																										
Inductive half and full bridge	mH	2.5 ... 20 (V _B = 2.5 V) 6 ... 19 (V _B = 1 V)																																																																																										
Absolute calibration accuracy	%	better 0.5																																																																																										
Perm. cable length between transducer and amplifier	m	500 ¹⁾ max.																																																																																										
Carrier frequency amplifier																																																																																												
Measuring ranges Strain gage	mV/V	± 0.1000 ... 3.0600 (V _B = 5 V) ± 0.2000 ... 6.1200 (V _B = 2.5 V) ± 0.5000 ... 15.3000 (V _B = 1 V)																																																																																										
Inductive		± 1.5000 ... 45.9000 (V _B = 5 V) ± 3.0000 ... 91.8000 (V _B = 2.5 V) ± 7.500 ... 229.500 (V _B = 1 V)																																																																																										
Bridge balance range Strain gage	mV/V	± 3.0600 (V _B = 5 V) ± 6.1200 (V _B = 2.5 V) ± 15.3000 (V _B = 1 V)																																																																																										
Inductive		± 45.900 (V _B = 5 V) ± 91.8000 (V _B = 2.5 V) ± 229.500 (V _B = 1 V)																																																																																										
Measuring frequency range Butterworth low pass		<table border="1"> <thead> <tr> <th>Nom. val. (Hz)</th> <th>fc -1dB (Hz)</th> <th>-3dB (Hz)</th> <th>Phase del. (ms)</th> <th>Rise time (ms)</th> <th>Over-shoot %</th> </tr> </thead> <tbody> <tr><td>3000</td><td>3100</td><td>3600</td><td>0.33</td><td>0.13</td><td>16</td></tr> <tr><td>1000</td><td>1010</td><td>1165</td><td>0.66</td><td>0.35</td><td>12</td></tr> <tr><td>500</td><td>500</td><td>588</td><td>0.9</td><td>0.64</td><td>11</td></tr> <tr><td>250</td><td>246</td><td>291</td><td>1.45</td><td>1.3</td><td>10</td></tr> <tr><td>80</td><td>79</td><td>99</td><td>3.65</td><td>3.8</td><td>9</td></tr> <tr><td>40</td><td>37.5</td><td>49.5</td><td>6</td><td>7</td><td>7</td></tr> <tr><td>20</td><td>19</td><td>25.5</td><td>11</td><td>13.3</td><td>6</td></tr> <tr><td>10</td><td>8.9</td><td>12.4</td><td>20</td><td>26</td><td>5</td></tr> <tr><td>5</td><td>4.5</td><td>6.2</td><td>42</td><td>50</td><td>4</td></tr> </tbody> </table>	Nom. val. (Hz)	fc -1dB (Hz)	-3dB (Hz)	Phase del. (ms)	Rise time (ms)	Over-shoot %	3000	3100	3600	0.33	0.13	16	1000	1010	1165	0.66	0.35	12	500	500	588	0.9	0.64	11	250	246	291	1.45	1.3	10	80	79	99	3.65	3.8	9	40	37.5	49.5	6	7	7	20	19	25.5	11	13.3	6	10	8.9	12.4	20	26	5	5	4.5	6.2	42	50	4																														
Nom. val. (Hz)	fc -1dB (Hz)	-3dB (Hz)	Phase del. (ms)	Rise time (ms)	Over-shoot %																																																																																							
3000	3100	3600	0.33	0.13	16																																																																																							
1000	1010	1165	0.66	0.35	12																																																																																							
500	500	588	0.9	0.64	11																																																																																							
250	246	291	1.45	1.3	10																																																																																							
80	79	99	3.65	3.8	9																																																																																							
40	37.5	49.5	6	7	7																																																																																							
20	19	25.5	11	13.3	6																																																																																							
10	8.9	12.4	20	26	5																																																																																							
5	4.5	6.2	42	50	4																																																																																							
Bessel low pass		<table border="1"> <thead> <tr> <th>Nom. val. (Hz)</th> <th>fc -1dB (Hz)</th> <th>-3dB (Hz)</th> <th>Phase del. (ms)</th> <th>Rise time (ms)</th> <th>Over-shoot %</th> </tr> </thead> <tbody> <tr><td>900</td><td>900</td><td>1550</td><td>0.47</td><td>0.25</td><td>4.1</td></tr> <tr><td>400</td><td>445</td><td>805</td><td>0.7</td><td>0.45</td><td>1.3</td></tr> <tr><td>200</td><td>235</td><td>410</td><td>1.1</td><td>0.86</td><td>1.3</td></tr> <tr><td>100*)</td><td>117</td><td>210</td><td>1.8</td><td>1.7</td><td>1.3</td></tr> <tr><td>40</td><td>38.5</td><td>68</td><td>4.3</td><td>5.1</td><td>1</td></tr> <tr><td>20</td><td>22</td><td>37.5</td><td>7.4</td><td>9.4</td><td>1</td></tr> <tr><td>10</td><td>10.5</td><td>19</td><td>12</td><td>19</td><td>0</td></tr> <tr><td>5</td><td>5.1</td><td>9.6</td><td>22</td><td>35.5</td><td>0</td></tr> <tr><td>2.5</td><td>2.6</td><td>4.8</td><td>50</td><td>70</td><td>0</td></tr> <tr><td>1.25</td><td>1.35</td><td>2.4</td><td>100</td><td>135</td><td>0</td></tr> <tr><td>0.5</td><td>0.7</td><td>1.2</td><td>200</td><td>280</td><td>0</td></tr> <tr><td>0.2</td><td>0.17</td><td>0.3</td><td>650</td><td>1100</td><td>0</td></tr> <tr><td>0.1</td><td>0.08</td><td>0.15</td><td>1400</td><td>2200</td><td>0</td></tr> <tr><td>0.05</td><td>0.043</td><td>0.075</td><td>3000</td><td>4600</td><td>0</td></tr> </tbody> </table>	Nom. val. (Hz)	fc -1dB (Hz)	-3dB (Hz)	Phase del. (ms)	Rise time (ms)	Over-shoot %	900	900	1550	0.47	0.25	4.1	400	445	805	0.7	0.45	1.3	200	235	410	1.1	0.86	1.3	100*)	117	210	1.8	1.7	1.3	40	38.5	68	4.3	5.1	1	20	22	37.5	7.4	9.4	1	10	10.5	19	12	19	0	5	5.1	9.6	22	35.5	0	2.5	2.6	4.8	50	70	0	1.25	1.35	2.4	100	135	0	0.5	0.7	1.2	200	280	0	0.2	0.17	0.3	650	1100	0	0.1	0.08	0.15	1400	2200	0	0.05	0.043	0.075	3000	4600	0
Nom. val. (Hz)	fc -1dB (Hz)	-3dB (Hz)	Phase del. (ms)	Rise time (ms)	Over-shoot %																																																																																							
900	900	1550	0.47	0.25	4.1																																																																																							
400	445	805	0.7	0.45	1.3																																																																																							
200	235	410	1.1	0.86	1.3																																																																																							
100*)	117	210	1.8	1.7	1.3																																																																																							
40	38.5	68	4.3	5.1	1																																																																																							
20	22	37.5	7.4	9.4	1																																																																																							
10	10.5	19	12	19	0																																																																																							
5	5.1	9.6	22	35.5	0																																																																																							
2.5	2.6	4.8	50	70	0																																																																																							
1.25	1.35	2.4	100	135	0																																																																																							
0.5	0.7	1.2	200	280	0																																																																																							
0.2	0.17	0.3	650	1100	0																																																																																							
0.1	0.08	0.15	1400	2200	0																																																																																							
0.05	0.043	0.075	3000	4600	0																																																																																							
High-pass	from 0.2 Hz Be; 5 Hz Bu from 2.5 Hz Be; 5 Hz Bu from 20 Hz Be; 40 Hz Bu	Hz Hz Hz																																																																																										
		0.1 1.0 10																																																																																										

*) Factory setting

1) 100 m max. distance between connection board and T-ID/TEDS module

ML55BS6 single-channel amplifier module (continued)

Max. permissible common-mode voltage	V	± 6 V	
Common-mode rejection	dB	> 77 (0 ... 9600 Hz)	
Max. differential voltage DC	V	± 1	
Linearity deviation	%	< 0.02 typ. 0.01 ¹⁾	
Noise	μV/V _{pp}	Strain gage < 2 (0...1500 Hz) < 1 (0...100 Hz) < 0.2 (0...1.25 Hz)	Inductive < 100 (0...1500 Hz) < 50 (0...100 Hz) < 5 (0...1.25 Hz)
Long-term drift over 48 hours (Autocalibration on / off)	μV/V	< 0.2 / 0.4	< 20 / 60
Effect of a 10 K-change of the ambient temperature on the digital signals S1 (gross) and S2 (net): with autocalibration on: sensitivity zero point with autocalibration off: sensitivity zero point	% μV/V % μV/V	Strain gage 0.2 4	Inductive < 0.02 < 0.2 60
Analog outputs V_{o1} and V_{o2}			
Residual carrier voltage	mV _{pp}		< 6
Long-term drift (over 48 h)	mV		< 3

¹⁾ For measuring ranges > 1 mV/V strain gage (V_B = 5 V) or > 30 mV/V inductive; otherwise < 0.2 %

Connection boards for single-channel amplifiers

AP01i



AP 02

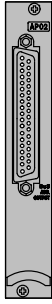

AP01i (connection board with D-female receptacle)		
Width	mm	20.3 (4 divs)
Transducer connection		D15 female receptacle, DA-15P ¹⁾
Output-signal connection		D25 female receptacle, DB-25P ²⁾
Option		2x EM001; 2x RM001 with AP02
Weight, approx.	kg	0.3

AP02 (Relay module)		
Width	mm	20.3 (4 divs)
Output-signal connection		D37 female receptacle, DC-37P ³⁾
Option		2x RM001
Weight, approx.	kg	0.3

AP03i

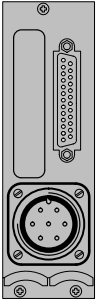

AP03i (connection board with MS-female device receptacle)		
Width	mm	40.6 (8 divs)
Transducer connection		7-pin MS-female receptacle, MS3106A 16S-1P ⁴⁾
Output-signal connection		D25 female receptacle, DB-25P ²⁾
Option		2x EM001, 2x RM001 with AP02
Weight, approx.	kg	0.3

AP07/1 for connection of T3..FNA and T10.. torque transducers		
Width	mm	40.6 (8 divs)
Torque-transducer supply supply during measurement	V_{pp}	54
supply for calibration	V_{pp}	81
Frequency	kHz	15 ... 20

AP07/1

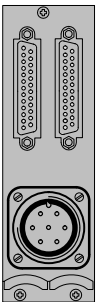

Transducer connection		7-pin MS-female receptacle, MS3106A 16S-1P ⁴⁾
Output-signal connection		D25 female receptacle, DB-25P ²⁾
Option		EM001; RM001
Weight, approx.	kg	0.5

AP08 for piezoelectric transducers					
Width	mm	20.3 (4 divs)			
Connections		BNC-female receptacle, isolated D25 female receptacle			
Range capacitors C_g	nF	0.1	1	10	100
Measuring ranges	pC	30...100	50...1000	500...10000	5000...100000
Accuracy					
Measuring range ≤ 100 pC	%	$\leq \pm 2.5$			
Measuring range ≥ 100 pC	%	$\leq \pm 1$			
Measuring frequency range					
≤ 1000 pC/ $C_g=100$ pF, 1 nF	kHz	100 (-1 dB)			
10000 pC/ $C_g=10$ nF	kHz	15 (-1 dB)			
100000 pC/ $C_g=100$ nF	kHz	1.5 (-1 dB)			
Linearity deviation	%	± 0.25 full scale			
Low pass filter	-	according to the data sheets of ML01B and ML10B			
Option	-	1xEM001; 2xRM001 with AP02			

AP08



- 1) HBM-order number 3-3312.0182
- 2) HBM-order number 2-9278.0293
- 3) HBM-order number 2-9278.0294
- 4) HBM-order number 1-MS3106 PEMV

Connection boards for single-channel amplifiers (continued)

AP08



AP08 (continued)		
Time constant ($t = C_g \cdot R_g$)		
Long	-	-
Medium ($R_g = 100 \text{ G}\Omega$)	s	10...10000
Short ($R_g = 1 \text{ G}\Omega$)	s	0.1...100
Maximum cable length		
Range capacitor $C_g = 100 \text{ pF}$	m	100
Range capacitor $C_g \geq 1 \text{ nF}$	m	200
Zero offset (during zero/measure changeover)	pC	$< \pm 1$
Drift (at 20°C)	pC/s	0.1
Effect of a 10K-change of the ambient temperature		
on the sensitivity	%	0.2 full scale
on the zero point	%	0.1 full scale
Operating temperature range	°C [°F]	-20...+60 [-4...+140]
Low pass filter	-	according to the data sheets of ML01B and ML10B
Weight, approx.	kg	0.3

AP09

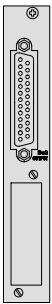

AP11i



AP09 for connection of thermocouples		
Width	mm	20.3 (4 divs)
Accuracy		
with 25°C	°C	± 0.3
with 20 ... 60°C	°C	± 1
Transducer connection		Terminal screws (0.5...1.5 mm ²)
Temperature cold junction		Semiconductor temperature-sensor at the terminal screw
Reference-point measuring range	°C [°F]	-20...+60 [-4...+140]
Option		2x EM001; 2x RM001 with AP02
Weight, approx.	kg	0.3

AP11i (connection board with Lemo-female device receptacle)		
Width	mm	20.3 (4 divs)
Transducer connection		6-pin Lemo [®] FGG.1B.306 ¹⁾
Output-signal connection		D25 female receptacle, DB-25P ²⁾
Option		2x EM001; 2xRM001 with AP02
Weight, approx.	kg	0.3

¹⁾ HBM order number 3-3312.0126

²⁾ HBM order number 2-9278.0293

AP13i



AP13i for PLC I/O cards; all inputs and outputs are electrically isolated by optical couplers		
Width	mm	20.3 (4 divs)
Outputs (short-circuit proof; protective circuit for inductive loads)		
Number		5
Separate ground systems		2
Nominal (rated) voltage (ext. supply)	V	24
Permissible voltage range	V	6...48
Output current	A	max. 0.5
Short-circuit current	A	0.8
Perm. short-circuit duration		no limit
Switching frequency on resistive load	Hz	max. 500
Input/Output		D-female receptacle 15/25-pin
Option		1x EM001
Inputs		
Number		8
Separate ground systems		4
Input voltage for		
Low-level	V	< 5
High-level	V	> 10
Input current at 24 V	mA	12
Current consumption		
internal 5 V	mA	13
external 24 V	mA	7.5 (without load)
Maximum power loss	W	10.5
Perm. short-circuit duration		unlimited
Permissible lead length	m	approx. 1000
Weight, approx.	kg	0.3

Connection boards for single-channel amplifiers (continued)

AP14



AP14 for Single S.G.		
Width	mm	20.3 (4 divs)
Options	-	1 EM001 output stage module; 2x RM001 with AP02
Accuracy class		
Full bridge	%	0.1
Half bridge	%	0.5
Quarter bridge	%	0.5
Transducers that can be connected		strain gage half and full bridges, single strain gages in 3-wire or 4-wire-technique
Amplifier modules that can be connected		ML10B, ML30B, ML55B
Connections		D15 female receptacle, DB25P
Transducer		D25 female receptacle, DB25P
Analog output, control signals		
Internal completion resistors	Ω	120, 350, 700
Max. perm. cable length between transducer and connection board	m	500
Linearity deviation	%	0.05
Measurement frequency range	kHz	0...50
Effect of a 10 K change of ambient temperature		
on zero point	%	Full bridge: 0.05
on measurement sensitivity	%	Quarter, Half bridge: 0.5
Operating temperature range	°C [°F]	-20...+60 [-4...+140]
Weight, approx.	kg	0.3

AP17



AP17 for connecting T10F-SF1, T10F-SU2 torque flanges and frequency signals to ML60B		
Width	mm	20.3 (4 divs)
Transducer connection		D15 female receptacle, DA-15P ¹⁾
Analog output/control signals		D25 female receptacle DB-25P ²⁾
Nominal (rated) temperature range	°C [°F]	-20 ... +60 [-4 ... +140]
Option		1x EM001, 2xRM001 with AP02
Weight, approx.	kg	0.3
Outputs		
Transducer supply	V (DC)	+16 (max. 500 mA) ³⁾
	V (DC)	-16 (max. 500 mA) ³⁾
	V (DC)	+5 (max. 300 mA) ³⁾
Release of calibration signal	V (DC)	approx. 5 (max. 100 mA)
Inputs		
Nominal (rated) input voltage		
symmetrical	V _{PP}	10
asymmetrical	V _{PP}	5
Minimum/maximum voltage swing		
symmetrical	V _{PP}	0.3/14
asymmetrical	V _{0P}	3/20
Common-mode voltage range	V	-5 ... +4
Maximum input frequency	kHz	1000 (with ML60B max. 200)

¹⁾ HBM order number 3-3312.0182

²⁾ HBM order number 2-9278.0293

³⁾ The specified current values are the maximum permissible permanent currents for AP17. The number of connection boards per housing is not limited, however, a maximum of three connection boards can be used for the transducer supply (5 V/16 V e.g. for T10F-SF1 torque flange).

Connection boards for single-channel amplifiers (continued)

AP18i



AP18i for current-fed piezoelectric transducers			
Accuracy class	%	1	
Width	mm	20.3 (4 divs)	
Transducer excitation	mA	2.5...20 (adjustable) 4 (factory setting)	
Current-source dynamic impedance	k Ω	30 typ.	
Input voltage range	V	12 \pm 9 (3...21 V)	
Load resistance	k Ω	>5	
Input sensitivity	V	0.1; 1V; 10V (\pm 0.05 dB)	
Frequency response			
Input sensitivity 1 V	for -1 dB	Hz	0.18...15000
	for -3 dB	Hz	0.10...25000
Input sensitivity 0.1 V	for -1 dB	Hz	0.18...17000
	for -3 dB	Hz	0.10...31000
Input sensitivity 10 V	for -1 dB	Hz	0.18...22000
	for -3 dB	Hz	0.10...43000
Effect of a 10 K change in ambient temperature	%	0.04 of full scale	
Noise referred to the input (2 Hz...22.4 kHz)			
Input sensitivity 0.1 V	μ Vms	30	
Input sensitivity 1 V	μ Vms	30	
Input sensitivity 10 V	μ Vms	75	
Distortion			
at 1 kHz		dB	-70 (typ.)
at 8 kHz		dB	-60 (typ.)
Option		Current output stage	
Weight, approx.	kg	0.3	

ML455 multi-channel amplifier

ML455 + Connection board		AP455i/AP455iS6		
Accuracy class		0.05		
Accuracy	%	$\pm (0.05 \text{ of measured value} + 0.05 \text{ of full scale value})$		
Carrier frequency	Hz	4801.2 \pm 0.48		
Bridge excitation voltage ($\pm 5\%$)	V	2.5		
Connectable transducers^{*)} in 6- (5) wire technique		Strain-gage half- or full bridge Inductive half- or full bridge LVDT		
Permissible cable length between transducer and connection board⁵⁾	m	100		
Measuring ranges				
Strain-gage	mV/V	± 4		
Inductive	mV/V	± 100		
LVDT	mV/V	± 1000		
Transducer impedance				
Strain-gage half- or full bridge	Ω	120 ... 1000		
Inductive half- or full bridge, LVDT	mH	4 ... 330		
Noise at 25°C [77°F]				
Butterworth/Bessel		Strain-gage	Inductive	LVDT
1000 Hz/200 Hz	$\mu\text{V/V}$	< ± 3	< ± 30	< ± 140
80 Hz/40 Hz	$\mu\text{V/V}$	< ± 0.5	< ± 3	< ± 28
20 Hz/5 Hz	$\mu\text{V/V}$	< ± 0.2	< ± 1.5	< ± 14
5 Hz/1.25 Hz	$\mu\text{V/V}$	< ± 0.1	< ± 0.5	< ± 6
Linearity deviation	%	< 0.02		
Effect of a 10 K-change of the ambient temperature		Autocal on		Autocal off
on sensitivity	% ⁶⁾	< ± 0.01		< ± 0.03
on zero point	% ⁷⁾	< ± 0.005		< ± 0.01
Operating temperature range	°C [°F]	-20...+60 [-4 ... +140]		
Transducer connection		4x15-pin Sub-D 6-pin Lemo [®] FGG.1B.306 ⁸⁾		
Width	mm	20.3 (4 divs)		

*) The transducer type can be selected separately for each of the four subchannels

5) Use cable twisted and shielded in pairs with outer shield (e.g. HBM-no. 4-3301.0071)

6) Of measured value

7) Of full scale value

8) HBM order number 3-3312.0126

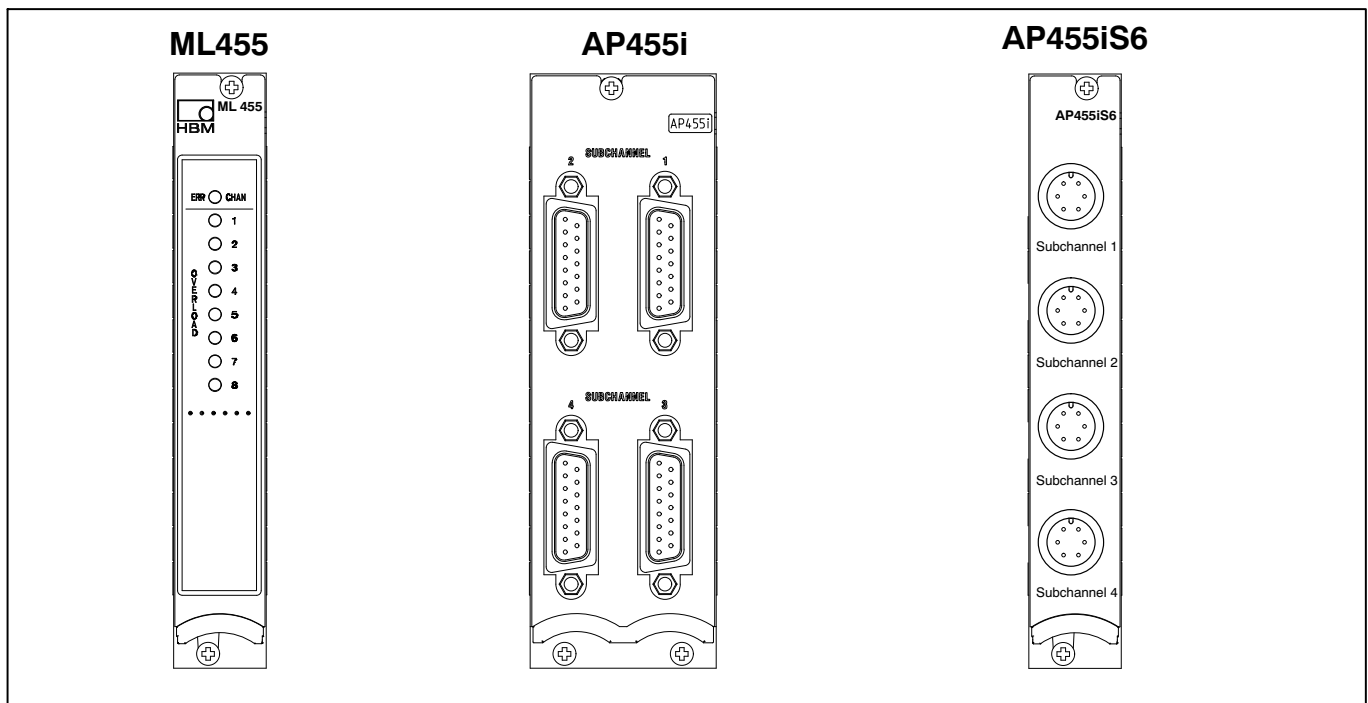

ML460 multi-channel amplifier module

ML460 + connection board		AP460i
Accuracy class	%	0.01 ¹⁾
Connectable transducers		
HBM torque transducers ²⁾		T4WA-S3, T3...FN/FNA, T10F...-KF1, T10F...-SF1, T10F...-SU2
Frequency signal sources with square-wave or sine-wave voltage, incremental transducers	kHz	0.0001...500
Inductive rotation speed measuring devices (T-R coils) using input filtering	kHz	0.5...200
Measuring ranges		
Frequency measurement	kHz	0...2 0...20 0...200 0...500
Accuracy, related to full scale value	%	0.01
Pulse counting	Pulses	100...1 000 000
Maximum impulse rate when pulse counting	Imp./s	500 000
Precision	Kimp	0.001
PWM carrier frequency	Hz	1...10 000
Precision	%/kHz	0.05
Pulse duration	ms	0 ... 2500
Precision	ms	0.001
Input frequency range	Hz	0.25 ... 10 000
Channel properties		
Number of subchannels		4
Class accuracy		0.01
Signals per subchannel F ₁ F ₂ Zero index		Frequency, pulse or PWM signal ±90° phase shift relative to F ₁ (direction detection) For detection of zero position in pulse counting
Electrical separation of all inputs from one another and from MGC ground	V	Typically 500 V
Input frequency range	kHz	0...500
Nominal (rated) temperature range	°C [°F]	-20 ... + 60 [-4 ... +140]
Operating temperature range	°C [°F]	-20 ... + 60 [-4 ... +140]
Storage temperature range	°C [°F]	-25 ... +70 [-13 ... +158]
Input signals		
Direct inputs, difference signals		
Input voltage range	V _{PP}	0.4 ... 30
Direct inputs, bipolar		
Input voltage range	V _{PP}	0.4 ... 30
Direct inputs, unipolar		
Input voltage range	V	5...30
Minimum pulse width	µs	3
Input for inductive transducer, filtered (F1 signals only)		
Required minimum input voltage (peak-to-peak)		
500 Hz		50 mV
1 kHz		100 mV
10 kHz		750 mV
25 kHz		1 V
50 kHz		1.5 V
75 kHz		2 V
100 kHz		2.5 V
125 kHz		3 V
150 kHz		4 V
175 kHz		5 V
200 kHz		7 V
Maximum input voltage	V	30
Input resistance F ₁ signal	kΩ	approx. 6

¹⁾ 0.05 in the case of PWM

²⁾ This torque transducers are not fed by the connection board AP460i!

ML460 multi-channel amplifier module (continued)

Transducer excitation								
Maximum current per channel 5 V 8 V 16 V		16 modules/device 10 mA 62.5 mA 62.5 mA	1 module/device 160 mA 600 mA 600 mA					
Measuring frequency range		Nom. val.	fc	-1dB	-3dB	Phase del.	Rise time	Over shoot
		(Hz)	(Hz)	(Hz)	(ms)	(ms)	(ms)	%
Without filter		-	740	1750	1	<0,6	0	
Low-Pass with Butterworth-Characteristic		500	450	550	1,5	1	9,4	
		250	250	290	2,5	2,1	12	
		80	83	99	5	6,2	8,5	
		40	41	49,5	7,5	13	7,8	
		20	20	25,5	12	24	7	
		10	9	12,4	25	50	4,7	
Low-Pass with Bessel-Characteristic		5	5	6,5	46	100	4,7	
		Nom. val.	fc	-1dB	-3dB	Phase del.	Rise time	Over shoot
		(Hz)	(Hz)	(Hz)	(ms)	(ms)	(ms)	%
		400	380	650	1,4	1	1	
		200	235	380	1,5	1,75	1	
		100 ^{*)}	125	210	2,6	3	2	
		40	43	70	5,2	7,5	1	
		20	24	40	7,4	15	1	
		10	11	18	15,7	31	0	
		5	4	10	27	55	0	
		2,5	2,6	4,8	53	125	0	
		1,25	1,35	2,4	104	210	0	
		0,5	0,7	1,2	195	450	0	
		0,2	0,17	0,3	730	2000	0	
	0,1	0,08	0,15	1480	3700	0		
	0,05	0,04	0,075	3000	7500	0		
Mechanical								
Card format	mm	Europe 100 x 160						
Width	mm	20.3 (4 divs)						
Connections		Lemo® 1B 10-pin EXG.1B.310.HLN						
Designation of suitable male connector (Manufacturer Lemo®)		Fixed plug (1st letter in model desig.) : F Key (3rd letter in model desig.) : G Series: 1B Type: 310 Example: FGG.1B.310.CLAD62 (Bold characters must be selected)						

ML460 multi-channel module and AP460i connection board

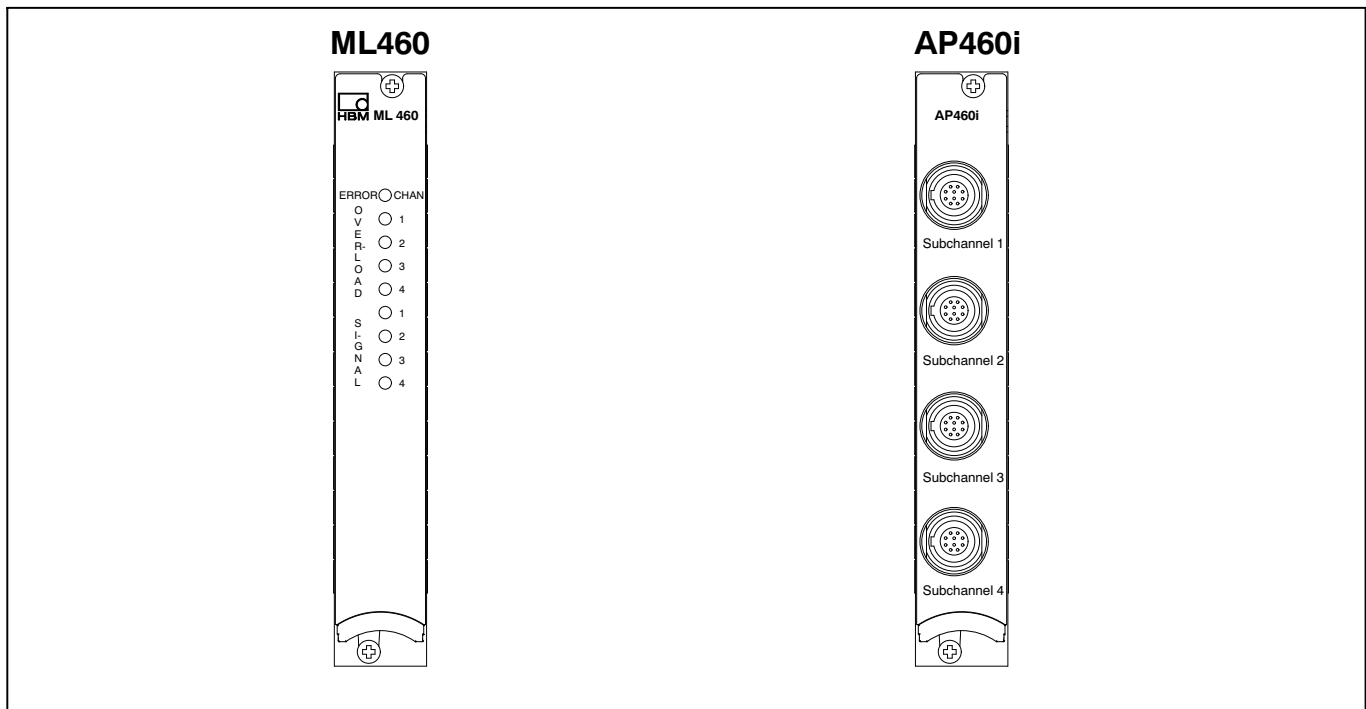

ML801B multi-channel amplifier

ML801B + connection board		AP801 ¹⁾	AP809 ²⁾	AP409 ³⁾	AP835 ⁴⁾
Accuracy class		0.05		0.2	0.05
Number of measuring points		8		4	8
Transducers		± 10 V symmetrical	Thermocouples Type K, J, T, E, N, B, R	Thermocouples Type K, J, T, E, N, B, R, Individual inputs electrically isolated	Pt100 4-wire circuit
Width	mm	20.3 (4divs)			
Maximum sampling rate per channel	Hz	2400 (8 subchannels), 4800 (4 subchannels), 9600 (2 subchannels) ⁵⁾			
Measuring frequency range	kHz	0 ... 1			
Effective resolution	Bit	20			
Maximum permissible input voltage and common-mode voltage	V	50	10	50	-
Absolute calibration deviation	%	0.05			
with cold junction	K	-	0.5		-
Filter	Butterworth low pass HD	Nominal (rated)	$f_{g \max -1dB}$	-3dB	Internal Sampling rate ⁶⁾
			(Hz)	(Hz)	(Hz)
		1000	1189	1518	9600
		500	523	691	9600
		250	253	322	9600
		200	203	265	9600
		80	78	103	9600
		1000	1206	1516	4800
		500	613	816	4800
		250	255	327	4800
		200	203	264	4800
		80	78	102	4800
		250	312	413	2400
		200	226	300	2400
		80	82	109	2400
		40	41	54	1200
		20	21	27	600
		10	10	13	300
		5	5,3	7	150
Filter	Bessel low pass HD	Nominal (rated)	$f_{g \max -1dB}$	-3dB	Internal Sampling rate ⁶⁾
			(Hz)	(Hz)	(Hz)
		200	259	448	2400
		100	102	184	2400
		40	41	75	2400
		20	20	36	2400
		10	10	18	2400
		5	5	9	1200
		2,5	2,5	4,5	600
		1	1	1,8	300
		0,5	0,5	0,9	150
		0,2	0,21	0,38	75
		0,1	0,1	0,19	37,5
		0,05	0,051	0,094	18,7

¹⁾ Connection plug on customer side: e. g. Phoenix Contact MC1.5/3-ST-3.5; Art. No. 1840379
(Connection plug for AP801S6: Lemo® FGG.0B.304.CLAD52)

²⁾ No line break recognition

³⁾ Two AP409 or two AP402i can be operated with one ML801B

⁴⁾ Connector plug provided by customer: Lemo® FFA.0S.304.CLA

⁵⁾ The number of subchannels can be changed by the MGCplus-setup-assistent or the MGCplus firmware loader

⁶⁾ The signals are converted internally at 38.4 kHz independent of the number of subchannels adjusted. Implementation of digital filters requires a reduction of the sampling rate (through repeated averaging and subsampling). This reduced sampling rate is called "internal sampling rate".

ML801B+Connection board		AP801	AP809	AP409	AP835
Filtre Butterworth low pass compatible		Nominal (rated) (Hz)	f_{g max} -1dB (Hz)	-3dB (Hz)	Internal Sampling rate (Hz)
		1000 500 250 200 80 40 20 10 5	1076 596 279 214 78,9 38,7 19,5 9,36 4,37	1282 798 345 266 103 51,8 27,2 13,2 6,4	4800 4800 2400 2400 2400 2400 2400 2400 1200
Bessel low pass compatible		Nominal (rated) (Hz)	f_{g max} -1dB (Hz)	-3dB (Hz)	Internal Sampling rate (Hz)
		200 100 40 20 10 5 2,5 1 0,5 0,2 0,1 0,05	322 125 41 21 11 5,5 2,7 1,36 0,68 0,186 0,093 0,047	571 216 70 37 19 9,6 4,8 2,4 1,2 0,186 0,158 0,079	2400 2400 2400 2400 2400 2400 1200 600 300 75 37,5 18,7
Input for voltage measurement					
Input signal range	V mV	-10.5...+10.5	-80...+80	-80...+80	-
Zero offset	V mV	-10.5...+10.5	-80...+80	-80...+80	-
Internal resistance of the signal voltage source	kΩ		< 1.0		-
Input resistance symmetrical/asymmetrical	kΩ	500/250	2000/1000	1000	-
Noise rel. to input with filter setting 1.25 Hz	μV _{pp}	< 50	< 0.5	< 2	-
Long-term drift over 48 hours (Autocalibration on/off)	mV	0.8/1.5	0.01/0.02	0.02/0.05	-
Linearity deviation	%	<0.03; typ. 0.01	<0.03; typ. 0.01	<0.06; typ. 0.03	-
Transducer supply⁷⁾ (AP801S6 only)					
Transducer supply voltage (must in each case be selected for all channels collectively)	V	8/16	-	-	-
Max. output current for external transducers	mA	50	-	-	-

⁷⁾ A total of max. 1 A for transducers supply may be withdrawn from the MGCplus.

ML801B multi-channel amplifier (continued)

ML801B + Connection board		AP801	AP809	AP409	AP835
Input for thermocouples					
Linearisation error	°C	-	< 0.06	< 0.25 (K, J, T, E, N)	-
	°C	-	-	< 0.6 (S, B, R)	-
Linearisation range	NiCr-Ni (K)	-	-158...+1414	-191...+1414	-
	Fe-CuNi (J)	-	-167...+1192	-190...+1192	-
	Cu-CuNi (T)	-	-210...+393	-237...+393	-
	NiCr-CuNi (E)	-	-161...+1005	-205...+1005	-
	NiCrSi-NiSi (N)	-	-186...+1300	-219...+1300	-
	Pt30Rh-Pt6Rh (B)	-	+570...+1814	+160...+1814	-
	Pt13Rh-Pt (R)	-	+178...+1769	-50...+1769	-
Temperature range of cold junction	°C	-	-20...+60		-
Long-term drift over 48 h with/without autocalibration					
	Type K, J, T, E, N	-	0.2/0.4	0.5/1	-
	Type B, R	-	1.0/2.0	2/3	-
Noise with 1.25 Hz filter					
	Type K, J, T, E, N	-	< 0.1	< 0.1	-
	Type B, R	-	< 0.3	< 0.3	-
Input for Pt100					
Measuring range	Ω	-	-	-	500
Linearisation error	°C	-	-	-	< 0.02
Linearisation range	°C	-	-	-	-200 ... +848
Noise voltage with 1.25 Hz filter	mΩ _{pp}	-	-	-	2
Measuring current	mA	-	-	-	0.5
Permissible cable length between transducer and amplifier	m	-	-	-	300
Linearity deviation	K	-	-	-	± 0.1
Long-term drift over 48h with autocalibration	mΩ	-	-	-	< 30

1) 100 m max. distance between connection board and T-ID/TEDS module

ML801B + Connection board		AP401
Accuracy class	%	0.1
Measuring range	V	± 10
Max. common mode input voltage (to housing/ground)	V	± 45
Max. differential input voltage	V	± 70
Input impedance	MΩ	20
Common-mode rejection (with 50 Hz, 20 V _{pp}) (with DC ± 10 V)		typ. 75 min. 100
Measurement frequency range	Hz	1000 (-1 dB)
Linearity deviation	%	± 0.03
Effect of a 10K-change of the ambient temperature on zero point (related to full scale)		
Autocal on	%	max. ± 0.02
Autocal off	%	max. ± 0.05
on sensitivity		
Autocal on	%	max. ± 0.02
Autocal off	%	max. ± 0.05
ESD resistance channel to housing/ground	V (DC)	± 400
ESD resistance channel to channel	V (DC)	± 400
Transducer connection		4-pole female connector, compatible to Lemo® Serie S, Size 0, contact arrangement 304, fitting connector: e.g. FFA 0S 304 CLAC52 (Lemo®)
Width	mm	20.3 (4 divs)
Operating temperature range	°C [°F]	-20...+60 [-4...+140]

ML801B multi-channel amplifier (continued)

ML801B + Connection board		AP402i ¹⁾
Accuracy class	%	0.1
Measuring ranges	V mA	1, 10, 60 20
Potential separated measuring inputs	V DC	typ. 500
Max. common mode input voltage to (housing / ground)	V	100
Max. differential input voltage	V	70
Input impedance	MΩ	10
Measuring ranges 1V, 10V	MΩ	0.6
Measuring range 60V	Ω	45
Measuring range 20mA		
Common-mode rejection (with 50 Hz, 20Vpp) (with DC 10V)	dB dB	typ. 75 min. 100
Measurement frequency range	Hz	1000 (-1dB)
Linearity variation	%	0.03
Noise voltage Filter characteristics Measuring range 1V Measuring range 10V Measuring range 60V Measuring range 20mA greater than 45 Ohm	μVpp μVpp μVpp μVpp	5 Hz Bessel / 500 Hz Butterworth < 40 / < 300 < 400 / < 3000 < 2400 / < 18000 < 100 / < 500
Effect of a 10K-change of the ambient temperature on zero point (related to full scale) Autocal on Autocal off on sensitivity Autocal on Autocal off	% % % %	max. 0.02 max. 0.075 max. 0.05 (Measuring range 10V: max. 0.02) max. 0.1
Transducer connection		6-pin socket, compatible with Lemo [®] S series, size 0 Adapted plugs: e.g.: FGG.1B.306.CLA.441.D42 ²⁾ FGG.1B.306.CLA.441.D62
Transducer supply ³⁾ current carrying capacity potential separation	V DC mA -	Can be adjusted through jumper field: open, +5, +8 or +16 (for all subchannels) max. 100 (for all subchannels together) no
Transducer identification max. distance between TEDS module and AP402i potential separation	m	TEDS-capable (external TEDS modules only) 100 no
Nominal (rated) temperature range	°C [°F]	-20 ... +60 [-4...+140]
Operating temperature range	°C [°F]	-20 ... +60 [-4...+140]
Storage temperature range	°C [°F]	-25 ... +70 [-13...+158]
Width	mm	20.3 (4 divs)

¹⁾ Two AP409 or two AP402i can be operated with one ML801B

²⁾ HBM-order number 3-3312.0126

³⁾ A total of max. 1 A for transducers supply may be withdrawn from the MGCplus.

ML801B multi-channel amplifier (continued)

ML801B + Connection board		AP418i	
Accuracy class	%	1.0	
Connectable transducers ^{*)}		4 current-fed piezoelectric transducer (e.g. Deltatron™)	
Transducer identification		T-ID and TEDS compatible	
Transducer excitation	mA	4	
Input voltage range	V	2 ... 20	
Measuring ranges	V	± 0.05; ± 0.5; ± 5	
Measurement frequency range	Hz	1000 (-1 dB)	
Lower limit frequency (-3 dB)	Hz	0.72	
Linearity deviation	%	0.05	
Noise Filter characteristics Measuring range ± 0.05 V Measuring range ± 0.5 V Measuring range ± 5 V	 V _{PP} V _{PP} V _{PP}	5 Hz Bessel/500 Hz Butterworth < 25 μ/ < 25 μ/ < 100 μ/	
Effect of a 10K-change of the ambient temperature on zero point (related to full scale)	%	Measuring range ± 0.05 V 0.1	Measuring range ± 0.5 V und 5 V 0.03
Width	mm	20.3 (4 divs)	
Operating temperature range	°C [°F]	-20...+60 [-4...+140]	

^{*)} If the transducer connection cable is used outside of closed rooms or if the transducer connection cable is longer than 30 m, then this cable must be protected against high voltage with an additional, separately grounded shield. This can be achieved laying the cable in a metallic pipe or by using double shielded cables, where the external shield near by the connection board must be grounded (connect to ground or ground wire). For this purpose HBM recommend to use Triaxial cables.

ML801B + Connection board		AP810i			
Accuracy class	%	0.1			
Transducers that can be connected		8 S.G. half or full bridges			
Excitation voltage (DC)	V	10; 5; 2.5; 0.5			
Transducer resistance at V_B R _{min} (full bridge) R _{max}	 Ω Ω	10 V 330	5 V 160	2.5 V 120	0.5 V 120
Measuring ranges	mV/V	± 4 (V _B =10 V) ± 8 (V _B =5 V) ± 16 (V _B =2.5 V) ± 80 (V _B =0.5 V)			
Control signal (Shunt)	mV/V	approx. 1 (with 350 Ω S.G. full bridge) approx. 0.5 (with 350 Ω S.G. half bridge)			
Noise at 350 Ω Filter characteristics Filter frequency V _B =10V V _B =5V V _B =2.5V V _B =0.5V	 Hz μm/m μm/m μm/m μm/m	1.25/5 < ± 0.025 < ± 0.05 < ± 0.1 < ± 0.4	Bessel/Butterworth 40/80 < ± 0.15 < ± 0.3 < ± 0.6 < ± 3	200/500 < ± 1.8 < ± 3.5 < ± 7 -	
Transducer connection		D25 female receptacle			
Permissible cable length between transducer and connection board	m	200 (100 m max. distance between connection board and T-ID/TEDS module)			
Width	mm	20.3 (4 divs)			
Linearity deviation	%	0.05			
Measurement frequency range	Hz	1000 (-1 dB)			
Effect of a 10 K-change of the ambient temperature on zero point (related to full scale) on sensitivity	 % %	0.05 0.1			
Operating temperature range	°C [°F]	-20...+60 [-4 ... +140]			

ML801B multi-channel amplifier (continued)

ML801 B+ Connection board		AP814Bi	
Accuracy class	%	0.1 ¹⁾	
Transducers that can be connected		8 S.G. quarter bridges in three wire technique	
Internal completion resistors	Ω	120, 350, 700, 1000 ²⁾	
Excitation voltage (DC)	V	5; 2.5; 1; 0.5	
Measuring ranges	mV/V	± 8 (V _B =5 V) ± 16 (V _B =2.5 V) ± 40 (V _B =1 V) ± 80 (V _B =0.5 V)	
Control signal (Shunt)	mV/V	approx. 1 (at 350 Ω)	
Noise at 350 Ω Filter characteristics		Bessel/Butterworth	
Filter frequency	Hz	1.25/5	40/80
V _B =5 V	μm/m	< ± 0.05	< ± 0.3
V _B =2.5 V	μm/m	< ± 0.1	< ± 0.65
V _B =1 V	μm/m	< ± 0.25	< ± 1.5
V _B =0.5 V	μm/m	< ± 0.45	< ± 3.5
200/500			
Transducer connection		D25 female receptacle	
Perm. cable length between transducer and connection board	m	200 ³⁾⁴⁾	
Width	mm	20.3 (4 divs)	
Linearity deviation	%	0.05	
Measurement frequency range	Hz	500 (-1 dB)	
Effect of a 10 K-change of the ambient temperature on zero point (related to full scale)	%	0.1	
on sensitivity	%	0.1	
Operating temperature range	°C [°F]	-20...+60 [-4 ... +140]	

1) The effect of errors due to asymmetrical cable resistances is not allowed for in the accuracy class.

2) Optional

3) Use connection cable of ≥ 0.25 mm² wire cross section.

4) 100 m max. distance between connection board and T-ID/TEDS module

ML801B + Connection board		AP815i	
Accuracy class	%	0.1 ⁵⁾⁶⁾	
Transducers that can be connected		8 S.G. full bridges in six wire technique or 8 S.G. half bridges in six wire technique or 8 S.G. half bridges in five wire technique or 8 S.G. quarter bridges in four wire technique or 2 S.G. rosettes	
Internal completion resistors	Ω	120, 350, 700, (optional 1000)	
Total transducer resistance with half and full bridges	Ω	240 ... 4000 (2x120 ... 2000 with half bridges; 4x240 ... 4000 with full bridges)	
Excitation voltage (DC)	V	5; 2.5; 1; 0.5	
Measuring ranges	mV/V	± 8 (V _B =5 V) ± 16 (V _B =2.5 V) ± 40 (V _B =1 V) ± 80 (V _B =0.5 V)	
Control signal (Shunt)	mV/V	1.0078 ± 0.1 % (at 350 Ω)	
Noise at 350 Ω Filter characteristics		Bessel/Butterworth	
Filter frequency	Hz	1.25/5	40/80
V _B =5 V	μm/m	< ± 0.1	< ± 0.6
V _B =2.5 V	μm/m	< ± 0.2	< ± 1.2
V _B =1 V	μm/m	< ± 0.5	< ± 3
V _B =0.5 V	μm/m	< ± 1	< ± 6
200/500			
Transducer connection		2 D25 female receptacle (four channels each)	
Permissible cable length between transducer and connection board	m	200 ⁷⁾	
Width	mm	20.3 (4 divs)	
Linearity deviation	%	0.05	
Measurement frequency range	Hz	1000 (-1 dB)	
Effect of a 10 K-change of the ambient temperature on zero point (related to full scale)	%	0.1 ²⁾	
on sensitivity	%	0.1	
Operating temperature range	°C [°F]	-20...+60 [-4 ... +140]	

5) 0.2 with irradiation according to EN 6100-4-3:1996 + A1:1998

6) 0.2 with 5 V-excitation

7) 100 m max. distance between connection board and T-ID/TEDS module

ML801B multi-channel amplifier (continued)

ML801B + Connection board		AP836i		
Accuracy class	%	0.1		
Transducers that can be connected		8 x transducer in 5-wire circuit, 8 x voltage Ungrounded active transducers with 5V/10V voltage supply and voltage output, can be selected individually per channel		
Excitation voltage (DC)	V	5		
Transducer resistance				
R_{\min}	Ω	190		
R_{\max}	Ω	5000		
Measuring ranges				
Potentiometric transducers	mV/V	± 500		
Active transducers ¹⁾	V	± 10		
Noise		Bessel/Butterworth		
Filter characteristics	Hz	1.25/5	40/80	200/500
Filter frequency	mV/V	< ± 0.01	< ± 0.05	< ± 0.5
Transducer connection		D25 female receptacle		
Permissible cable length between transducer and connection board	m	200 (100 max. distance between connection board and T-ID/TEDS modul)		
Width	mm	20.3 (4 divs)		
Linearity deviation	%	0.05		
Measuring frequency range	Hz	500 (-1 dB)		
Effect of a 10 K-change of the ambient temperature on zero point (related to full scale)	%	0.05		
on sensitivity	%	0.1		
Operating temperature range	$^{\circ}\text{C}$ [$^{\circ}\text{F}$]	-20...+60 [-4 ... +140]		

¹⁾ Excitation voltage can be adjusted to 2.5 V; 5 V; 10 V through display and control panel or software.

Connection boards for multi-channel amplifiers

AP801

for 8 DC voltage sources

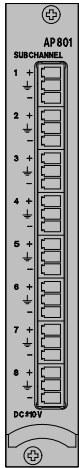

AP801S6

for 8 voltage sources
with voltage supply 8V/16V

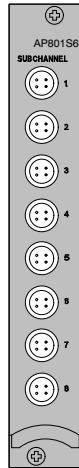

AP809

for 8 thermocouples



AP409

for 4 thermocouples

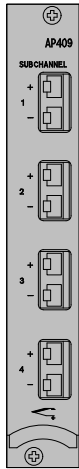

AP835

for 8 RTD Pt100

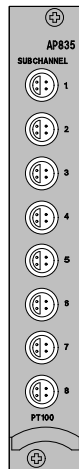

AP836i

for 8 potentiometric
Transducers

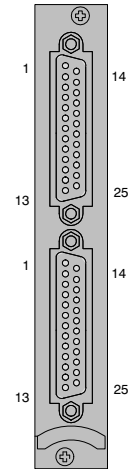

AP810i

for 8 S.G. half or full bridges

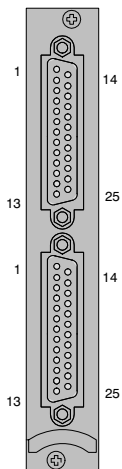

AP814Bi

for 8 S.G. quarter bridges
in three wire technique

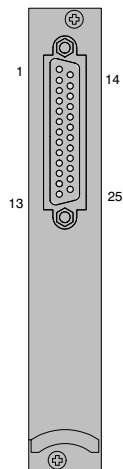

AP815i

for 8 S.G. quarter, half-
or full bridges

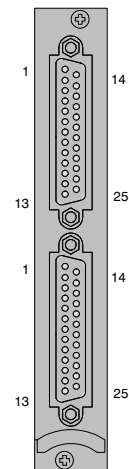

Connection boards for multi-channel amplifiers

AP401

for 4 DC-voltage supplies
(electrically isolated)

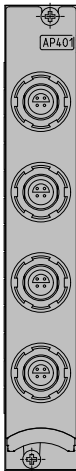

AP402i

For 4 DC voltage or current sources
(electrically isolated, TEDS capability,
with 5 V, 8 V, 16 V voltage supply)



AP418i

for 4 current-fed piezoelectric transducers
(compatible with T-ID and TEDS)



Programmable plug-in module ML70B¹⁾

Analogue outputs		
Max. number of analog outputs		2 (10 with AP78)
Analogue outputs update rate	Hz	2400
Nominal (rated) voltage	V	± 10V asymmetrical
Permissible load resistance	kΩ	>5
Internal resistance	Ω	< 5
Residual carrier voltage (76.6 kHz)	mV _{PP}	< 12
Long-term drift (over 48h)	mV	< 3
Effect of ambient temperature at 10°K: Sensitivity Zero point	% mV	< 0.08 typically 0.04 < 3 typically 2
Programming		
Programming language		IEC61131-3
Data program memory (volatile)	kByte	224
Data program memory (non-volatile)	kByte	16
Code program memory (volatile) (2 x available for online change)	kByte	2 x 160
Code program memory (non-volatile)	kByte	160
Memory for project sources (non-volatile)	kByte	192
Call frequency of the IEC program	Hz	2400, synchronized with MGCplus measured-value processing
Number of subchannels		1...128 (set by user)
Effective computer output		75,000 float operations/s or 300,000 integer operations/s
Mechanical		
Nominal (rated) temperature range	°C [°F]	-20 ... + 60 [-4 ...+140]
Operating temperature range	°C [°F]	-20 ... + 60 [-4 ...+140]
Storage temperature range	°C [°F]	-25 ... +70 [-13 ...+158]
Operating voltages	V	+14.6 ... +17.0 (<90 mA) -14.6 ... -17.0 (<100 mA) -7 ... -9 (<10 mA)
Card format	mm	Europe 100 x 160
Width	mm	20.3 (4 divs)
Connector		DIN 41612 indirectly
Supported connection boards		
Number of controllable connection boards		0, 1 or 2
Supported connection board types		AP71 (2 CAN interfaces) AP72 (2 serial interfaces) AP75 (8 Digital-In, 8 Digital-Out, 24V level) AP78 (8 analog outputs)

AP72 Connection board

Interfaces		
Baudrate	kBaud	9.6; 19.2; 38.4; 57.6; 115.2
Electrical isolation	V	Typ. 500
Connector		9-pol.Sub-D female receptacle
Mechanics		
Nominal (rated) temperature range	°C [°F]	-20 ... +60 [-4 ...+140]
Operating temperature range	°C [°F]	-20 ... +60 [-4 ...+140]
Storage temperature range	°C [°F]	-25 ... +70 [-13 ...+158]
Nominal (rated) voltages	V	+5 ... (< 100 mA)
Card dimensions	mm	102 x 112
Width	mm	20.3 (4 division units)

¹⁾ Only in systems with CP22, CP32 and CP42 or in systems without a communications processor.

ML70B Programmable module and AP72 Connection board

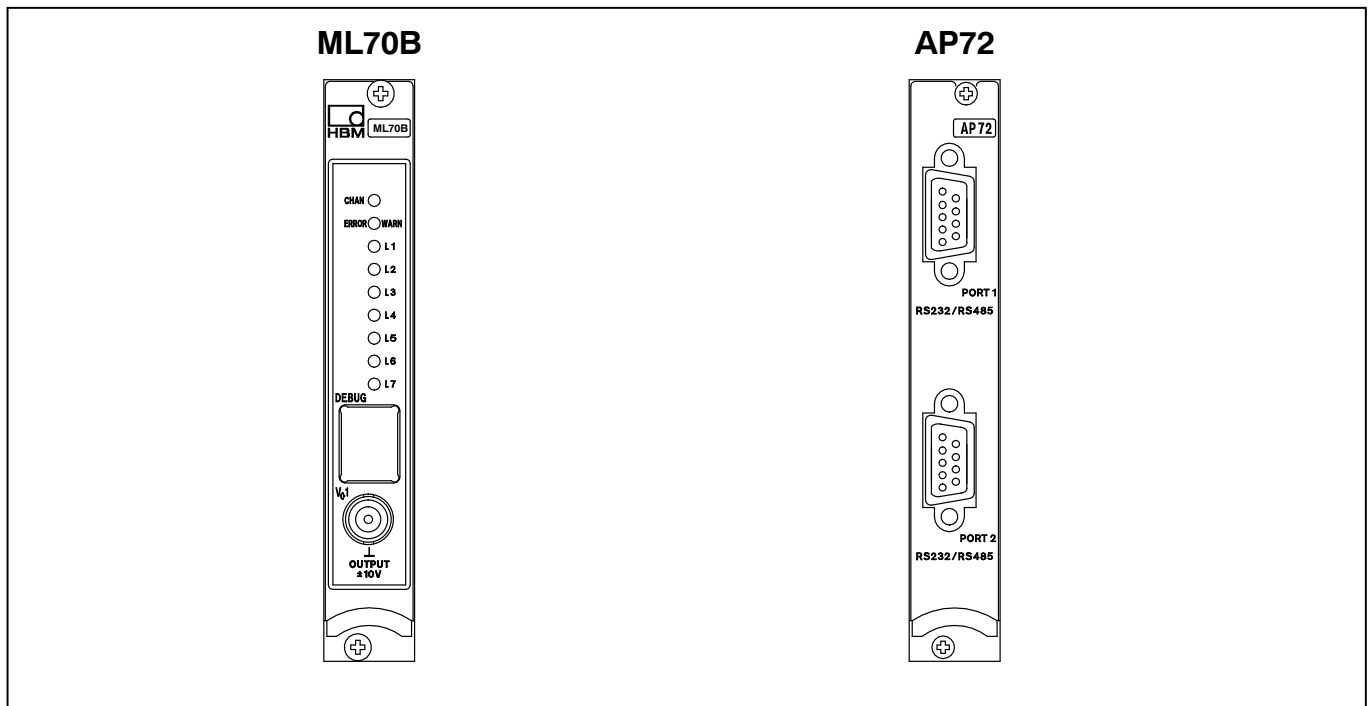

Communication card ML71B/ML71BS6 with AP71 Connection board (CANbus)¹⁾

CAN interface		
Number of CAN interfaces		2
Protocol		CAN 2.0B
Baud rate	Baud	10k 20k 50k 125k 250k 500k 1M
Line length	m	1000 1000 1000 500 250 100 25
Hardware bus link individually selectable for each CAN interface		Standard High Speed ISO 11898-24 V Fault Tolerant Low Speed
Connection technique		2x 9-pin DSUB, individual potential separation of supply and ground
Measurement recording		
Number of recordable signals		max. 128 each CAN-port ¹⁾
Max. number of signals (16 Bit signals each with 4 signals per message)		Signals per second
		25 50 100 400 1200
		128 72 36 8 ²⁾ 1 ... 8 ³⁾
Database with parameter information via the CAN signals		2 (one database per CAN interface)
Size of databases	Byte	2x 100k
Database storage		non-volatile in ML71B flash memory
Mechanical values		
Nominal (rated) temperature range	°C [°F]	-20 ... +60 [-4 ...+140]
Operating temperature range	°C [°F]	-20 ... +60 [-4 ...+140]
Storage temperature range	°C [°F]	-25 ... +70 [-13 ...+158]
Operating voltage	V	+14.6 ... +17.0 (< 90 mA) -14.6 ... -17.0 (< 100 mA) -7 ... -9 (< 10 mA)
Card format	mm	Europe 100 x 160
Width	mm	20.3 (4 divs)
Receptacle		DIN 41612 indirectly

¹⁾ Only in systems with CP22, CP32 and CP42 or in systems without a communications processor.

Communication card ML71B/ML71BS6 with AP71 Connection board (CANbus)

Analogue output		
The analogue output can display one of the max. 128 input signals at a time		
Nominal (rated) voltage	V	± 10 V asymmetrical
Permissible load resistance	kΩ	> 5
Internal resistance	Ω	< 5
Effect of a 10 K-change of the ambient temperature on the sensitivity	%	< 0.08 typ. 0.04
Non-linearity	%	< 0.05
Effect of a 10 K-change of the ambient temperature on zero point	mV	3 typ. 2

1) Max. 256 channels per CP42

2) While operating with more than 8 Sub-channels

3) While operating as 8-channel device

ML74 Communication card¹⁾

CANinterface				
Connection board		AP74		
Protocol		CAN 2.0B		
Baud rate	kBaud	250		
Line length	m	250		
Hardware bus link individually selectable for each CAN interface		ISO 11898		
Maximum bus length (without branches) ²⁾		120 Ohm; 2.5 V P=1.8W/CANHEAD	350 Ohm; 2.5 V P=1.15W/CANHEAD	700 Ohm; 2.5 V 1000 Ohm; 2.5 V P=1.0W/CANHEAD
No. of CANHEAD				
12		90	140	165
11		100	155	180
10		110	170	200
9		120	190	220
8		135	215	250
7		155	250	
6	m	180		
5		220		
4		250		
3				
2				
1				
Measurement recording				
Max. number of CANHEAD modules		12		
Number of sub-channels		10 ... 120 ³⁾		
CANHEAD power supply				
Cut off current	A	2		
Cut-off upon current to earth	A	0.1		
Mechanical values				
Nominal (rated) temperature range	°C	-20 ... +60		
Operating temperature range	°C	-20 ... +60		
Storage temperature range	°C	-25 ... +70		
Card format	mm	Europa 100 x 160		
Width	mm	20.3 (4 divs)		

1) Only in systems with CP22 and CP42 or in systems without a communications processor.

2) Thin Media Cable (0.38 mm²) at ambient temperature of 45 °C

3) Max. 256 channels each CP42

ML74 Communication card and AP74 Connection board

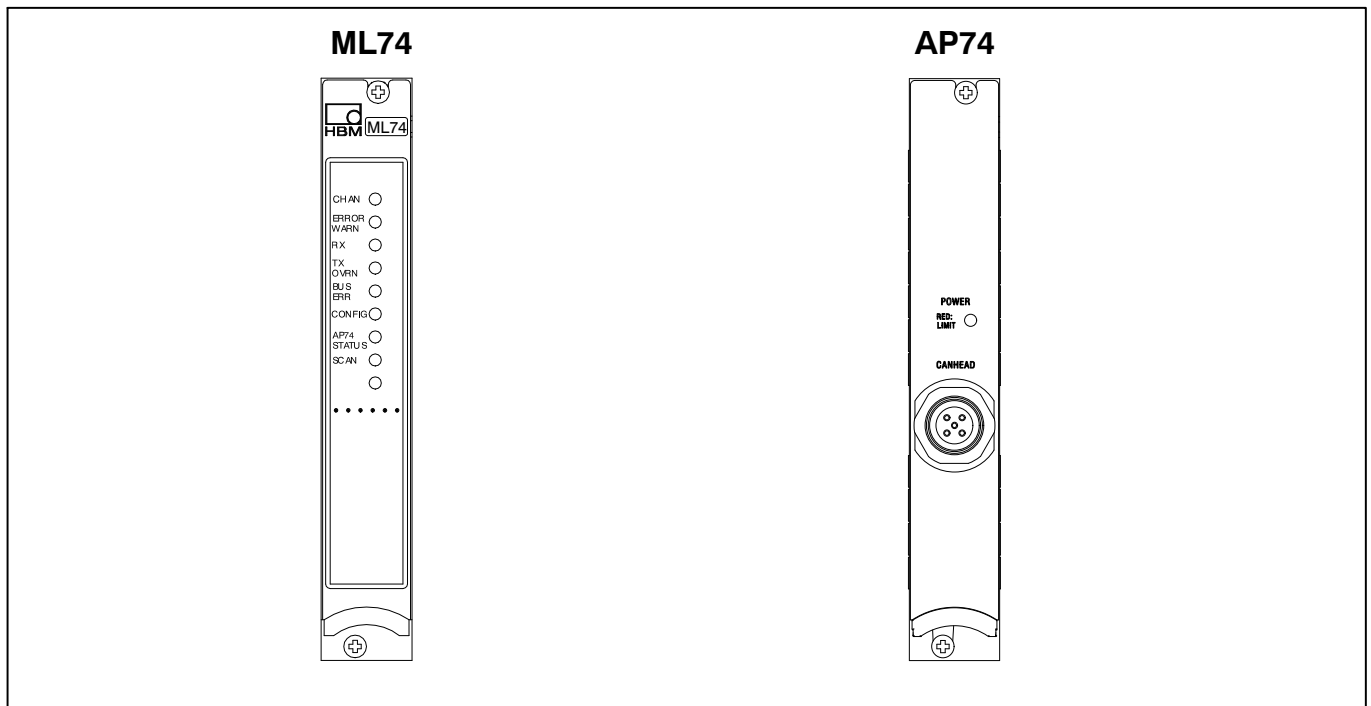

Communication card ML77B with AP77 Connection board (Profibus DP)¹⁾

Protocol		Profibus DP slave as per DIN 19245-3
Baud rate	Baud	9.6k ... 12M
Profibus ID number		04A9 (hexadecimal)
Potential separation	V	typ. 500
Connection technique		9-pin DSUB
Measurement transmission		
Supported formats		4 Byte Integer 2 Byte Integer 4 Byte Float (IEEE) 4 Byte Float (Siemens) 4 Byte raw values 2 Byte raw values
Transmission rate at Profibus		
Float; 24 signals	Hz	2400
Float; 48 signals	Hz	1200
Integer 32 Bit; 32 signals	Hz	2400
Integer 16 Bit; 48 signals	Hz	2400
Integer 16 Bit; 88 signals	Hz	1200
Integer 16 Bit; 120 signals	Hz	800
Measuring data updating for 15 channels and 1 signal/channel	1/s	1200
Mechanical values		
Nominal (rated) temperature range	°C [°F]	-20 ... +60 [-4...+140]
Service temperature range	°C [°F]	-20 ... +60 [-4...+140]
Storage temperature range	°C [°F]	-25 ... +70 [-13...+158]
Operating voltages	V	+14.6 ... +17.0 (< 120 mA) -14.6 ... -17.0 (< 120 mA) +7 ... +9 (<10 mA)
Card format (Euro)	mm	100 x 160
Width	mm	20.3 (4 divs)
Connector		DIN 41612 indirectly
Weight	kg	approx. 0.3

¹⁾ Only in systems with CP22 and CP42 or in systems without a communications processor.

Multi-channel I/O module ML78B¹⁾

ML78B + connection board		AP78	AP75
Analog outputs			
Max. number of analog outputs		10 (2 filterable outputs, 1 of which is also accessible via the front panel on the ML78)	2 (both outputs filterable 1 also accessible via the front panel on the ML78)
Electrical isolation	V	Typically 500 ²⁾	-
Analog outputs update rate	Hz		2400
D/A conversion resolution	bit		16
Grounding systems		2 ³⁾	1, isolated from dig. grounding systems
Nominal (rated) voltage	V		± 10 asymmetrical
Permissible load resistance	kΩ		≥ 5
Internal resistance	Ω		< 5
Residual carrier voltage (76.6 kHz)	mV _{PP}		< 12
Long-term drift (over 48 h)	mV		< 3
Effect of change in ambient temperature of 10 K	% mV		< 0.08; typically 0.04 < 3, typically 2
Digital inputs			
Max. number of digital inputs			8 (16) ⁴⁾
Input voltage range	V		0 ... 30 (nom. 0 ... 24 V)
Electrical isolation	V		Typically 500
Low potential	V		< 5
High potential	V		>10
Grounding systems			1, isolated from the digital output
Control functions for MGCplus channel groups			Autocalibration on/off; Reset; Tare; Peak value clear/hold; Synchronisation of internal curve generator
Digital outputs			
Max. number of digital outputs			8 (16) ⁴⁾
Output voltage range	V		0 ... 30 (nom. 0 ... 24V)
Output current	A		0.5
Short-circuit current	A		1.5
Electrical isolation	V		Typically 500
Response time (not for "external" mode)	ms		< 4
Grounding systems			1, isolated from the digital inputs
Excitation	V		18 ... 30 (nom. 24); external
Possible function assignment for the outputs			<ul style="list-style-type: none"> Combine Limit Value for up to 120 MGCplus channels Acknowledgement signal for input Settings by means of an external software command Overflow message for groups of measurement channels
Curve generator			
Max. number of curves			10
Update rate (each channel adjustable)	Hz		1; 2; 5; 10; 20; 50; 100; 200; 600; 1200; 2400
Max. number of curve points			≤ 128000, permanently storable in flash memory
Mechanical			
Nominal (rated) temperature range	°C [°F]		-20 ... + 60 [-4 ... +140]
Operating temperature range	°C [°F]		-20 ... + 60 [-4 ... +140]
Storage temperature range	°C [°F]		-25 ... + 70 [-13 ... +158]
Operating voltages	V		+14.6 ... +17.0 (< 100 mA)/ -17.0 ... -14.6 (< 90 mA)/ -9.0 ... -7.0 (< 10 mA)
Card format / width	mm		Euro 160 x 100 / 20.3 (4divs)
Connection technique		25-pin Sub-D	Plug-in screw terminals
Permissible connection board configurations		1 x AP78 / 1 x AP75 / 1 x AP78 and 1 x AP75 / 2 x AP75 ⁵⁾	

¹⁾ Only in systems with CP22, CP32 and CP42 or in systems without a communications processor.

²⁾ The filterable digital outputs are not electrically isolated!

³⁾ 1 grounding system for 2 digital filterable analog outputs and 1 grounding system for the remaining 8 analog outputs

⁴⁾ When using 2 AP75 connection boards: 16 digital inputs and 16 digital outputs

⁵⁾ Analog outputs V_{O1} and V_{O2} are both available on both connection boards

Connection board for Multi-channel I/O module ML78B

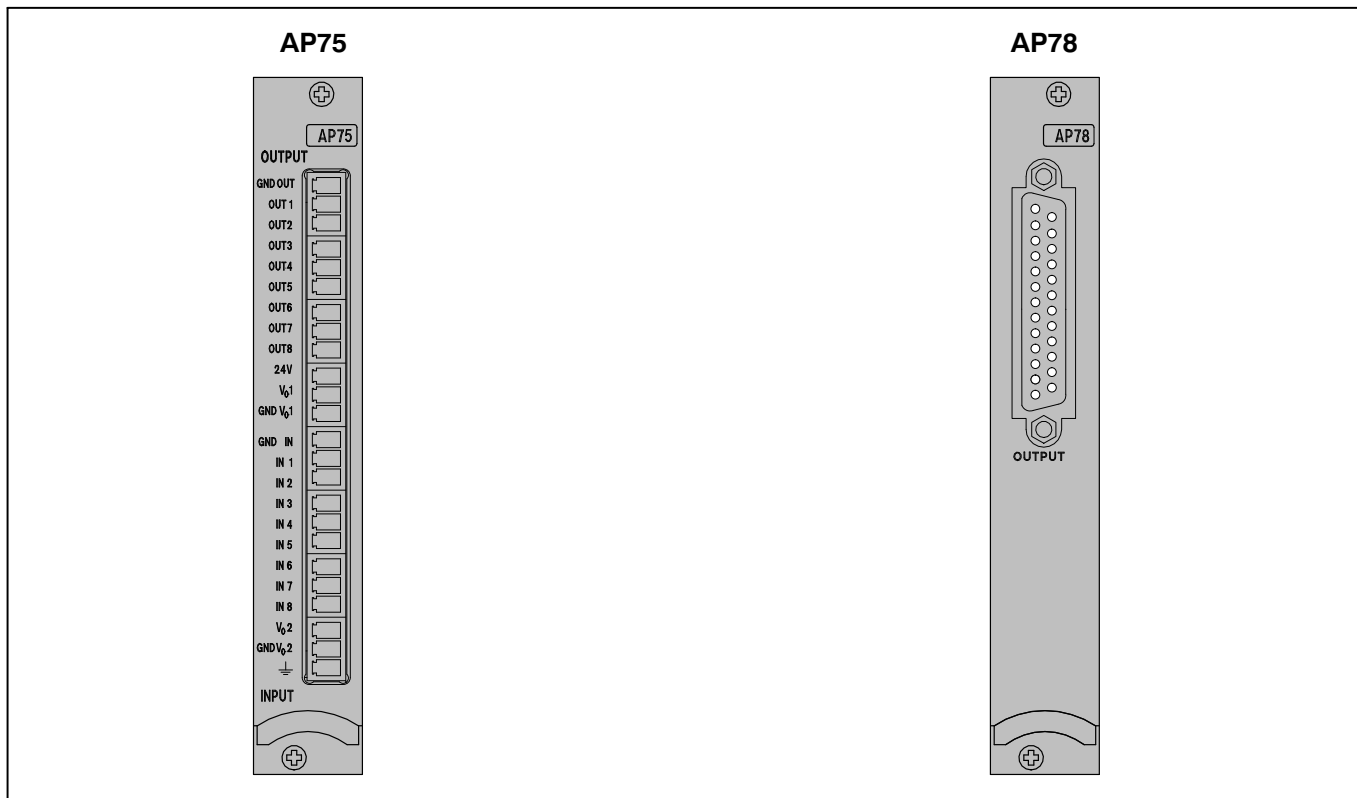

AB22A/AB32 Display and Control Panel

Width	111.8 mm (22 divs)
Display AB22A	Backlit LCD display, resolution 192x64 pixels
AB32	Vacuum-fluorescent display (VFD), resolution 192x64 pixels
Key panel	Keypad (alphanumeric), 4 function keys, cursor keys and dialog keys. All keys are touch-sensitive
Password	There is a facility for protecting certain operating levels with a password
Dialog	Menu languages: German/English/French/Spanish
Display formats	1, 3, 6 values; ty graph, xy graph; limit value status
Weight	approx. 0.5kg

ABX22A Portable Display and Control Unit

Illuminated display		no
Front width	mm	111.8 (22 divs)
Current consumption (8V)	mA	20
Length of cable (6-wire)	m	1.5
Receptacle type		Binder coupler receptacle, in accordance with DIN 45326, Series 723, 8-pin, No. 09-0171-15-08

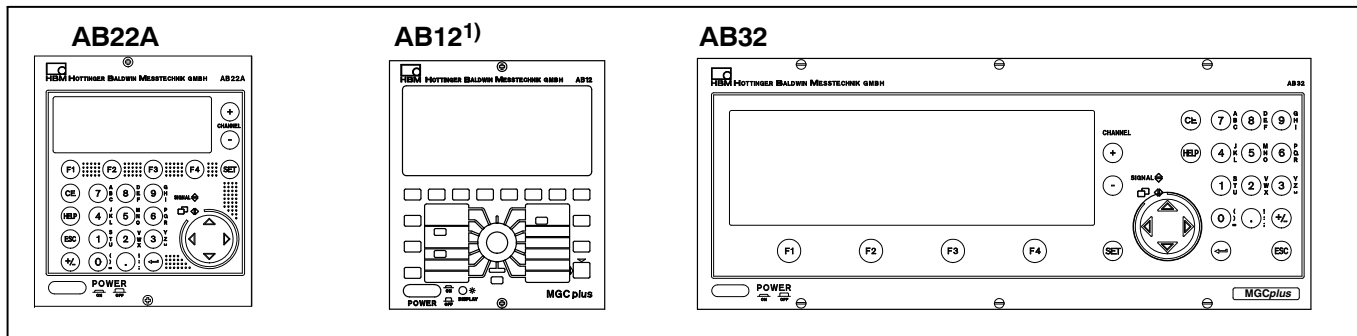

1) With single-channel amplifiers ML01B/10B/30B/35B/38B/50B/55B/60B only.

CP22 Communication processor

Width	mm	40.6 (8 divs)		
Interfaces		Potential separation	Connection technique	Baud rate
RS-232-C		No	9-pin D-sub female connector	38.4 kBaud
USB ²⁾ (master/slave)		No	USB female connector	12 MBaud (fast mode)
Ethernet		Yes	RJ45	10/100 MBaud
Data transfer rate				
Ethernet (64 channels/4Byte-measured values/ sampling rates 2400 Hz)	Measured values/s	153 600		
USB (24 channels/4Byte-measured values/ sampling rates 2400 Hz)	Measured values/s	57 600		
Nominal (rated) temperature range	°C [°F]	-20 ... +65 [-4 ... +149]		
Operating temperature range	°C [°F]	-20 ... +65 [-4 ... +149]		
Storage temperature range	°C [°F]	-25 ... +70 [-13 ... +158]		
Weight	kg	approx. 0.6		
I/O contacts				
Potential separation	V DC	500		
Connection technique 1 x In, 1 x Out, 24 V, GND		Screw terminals (line less than 30 meters long)		
Input voltage level LOW	V	0 ... 5		
Input voltage range HIGH	V	10 ... 24		
Input current, typically, high level = 24 V	mA	12		
Input current, typically, high level = 10 V	mA	3		
Output level active high at 0 A		Level supply minus 0.7 V		
Output level active high at 0.5 A		Level supply minus 3 V		
Power supply (external)	V	24 (11 V ... 30 V)		
Output current, max.	A	0.5		
Short-circuit current, typically	A	0.8		
Short-circuit period		unlimited		

²⁾ Cable length ≤ 5 m; Cable extensions are not permissible.

CP42 Communication processor

Width	mm	60,9 (12 divs)		
Interfaces		Potential separation	Connection technique	Baud rate
RS-232-C		typ. 500V	9-pin D-sub female connector	115.2 kBaud
USB ³⁾ (master/slave)		No	USB female connector	12 MBaud (fast-mode)
Ethernet		typ. 500V	RJ45	100 MBaud
Data transfer rate				
Ethernet (128 channels/sampling rate 2400 Hz)	Measured values/s	307 200 (4-byte format)		
USB (32 channels/sampling rate 2400 Hz)	Measured values/s	76 800 (4-byte format)		
PC card harddisk (approx. 109 channels/sampling rate 2400 Hz)	Measured values/s	262144 (4-byte format)		
(128 channels/sampling rate 2400 Hz)	Measured values/s	307200 (2-byte format)		
Nominal (rated) temperature range	°C [°F]	-10 ... +55 [+14 ... +131]		
Operating temperature range	°C [°F]	-10 ... +55 [+14 ... +131]		
Storage temperature range	°C [°F]	-25 ... +70[-13 ... +158]		
Weight	kg	approx. 0.6		
Extension (optional)		PC card harddisk, up to 5Gbyte, ATA standard		
I/O contacts				
Potential separation	V DC	500		
Connection technique 2 x In, 2 x Out, 24 V, GND		Screw terminals (line less than 30 meters long)		
Input voltage level LOW	V	0 ... 5		
Input voltage range HIGH	V	10 ... 24		
Input current, typically, high level = 24 V	mA	12		
Input current, typically, high level = 10 V	mA	3		
Output level active high at 0 A		Level supply minus 0.7 V		
Output level active high at 0.5 A		Level supply minus 3 V		

³⁾ Cable length ≤ 5 m; Cable extensions are not permissible.

Power supply (external)	V	24 (11 V ... 30 V)
Output current, max.	A	0.5
Short-circuit current, typically	A	0.8
Short-circuit period		unlimited

RM001 Relay module

Input voltage		V	0 / 5
Resistance		kΩ	12
Response time		ms	maximum 5
Release time		ms	maximum 25
Relay breaking capacity	max. voltage	V	42
	max current	A	1
	max. power	VA	30
Operating voltage		V	+8; -8
Power consumption		mA	34
Relay-module life	mechanical	Switching cycles	50 x 10 ⁶
	electrical (at nominal (rated) load)	Switching cycles	100 x 10 ³
Weight, approx		kg	0.1

EM001 Output stage module⁴⁾

Input			
Input voltage		V	-10 ... +10
Input resistance		kΩ	12.5
Output			
Impressed voltage		V	-10 ... +10
Impressed current		mA	± 20 / 4 ... 20
Load resistance		Ω	maximum 500 minimum 500
Measuring frequency range		kHz	10
Operating voltage		V	+16; -16
Power consumption		mA	35
Weight, approx		kg	0.1

⁴⁾ The EM001 output stage module can only be used with connection boards without transducer identification.

Modifications reserved.

All details describe our products in general form only. They are not to be understood as express warranty and do not constitute any liability whatsoever.

B0554-19.0 en

Hottinger Baldwin Messtechnik GmbH

Im Tiefen See 45, D-64293 Darmstadt, Germany
Tel.: +49 6151 8030; Fax: +49 6151 803 9100
E-mail: support@hbm.com www.hbm.com



measurement with confidence